

Porte-outils / Halter / Holders

H

Système de serrage monobloc
Einteiliges Klemmsystem
Monobloc top clamp system



H JET

Porte-outils avec arrosage intégré
Halter mit integrierter Kühlmittelzufuhr
Holders with integrated coolant supply

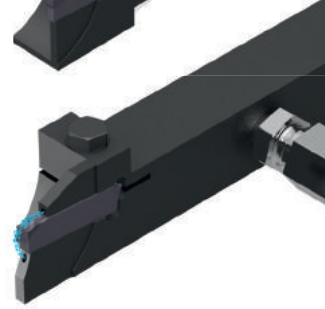

H-HM-JET
GWS-HM
MS-HM

Porte-lames avec arrosage
Halter für Stechklinge mit Kühlung
Holder for parting-off blades with coolant

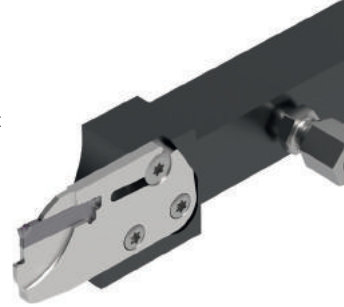

HM
HK
HUK

Lames
Stechklinge
Parting-off blades

Plaquettes / WSP / Inserts

ET 15

=

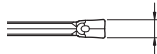

1.5 mm

Ø max 32 mm

ET 20

=

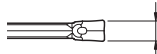

2.0 mm

ET 25

=

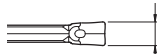

2.5 mm

ET 30

=

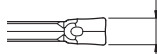

3.0 mm

Ø max 44 mm



U

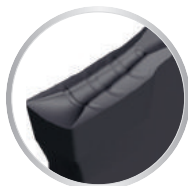

J



T



A

Very rigid clamping system!

Index

Informations techniques
Technisches Informationen
Technical information > **8.02**

Géométries de coupe
Spanformgeometrie
Cutting geometries > **8.04**

Nuances
Sorten
Grades > **8.05**

H Series sans arrosage
ohne Kühlung
without coolant > **8.06**

H JET Series avec arrosage
mit Kühlung
with coolant > **8.07**

H-HM-JET Series avec arrosage
mit Kühlung
with coolant > **8.08** **new**

GWS Series Göltenbodt > **8.09** **new**

MS Series Index > **8.13** **new**

Lames
Stecklingen
Blades **HM-HK-HUK Series** > **8.14**

U Series > **8.20**

J Series > **8.22**

T Series > **8.24**

A Series > **8.26**

Paramètres de coupe indicatifs
Empfohlene Schnittwerte
Standard machining data > **8.28**

Compact: seulement 20 mm pour les machines courantes

Kompakt: nur 20 mm für übliche Maschinen

Compact: only 20 mm for current machines

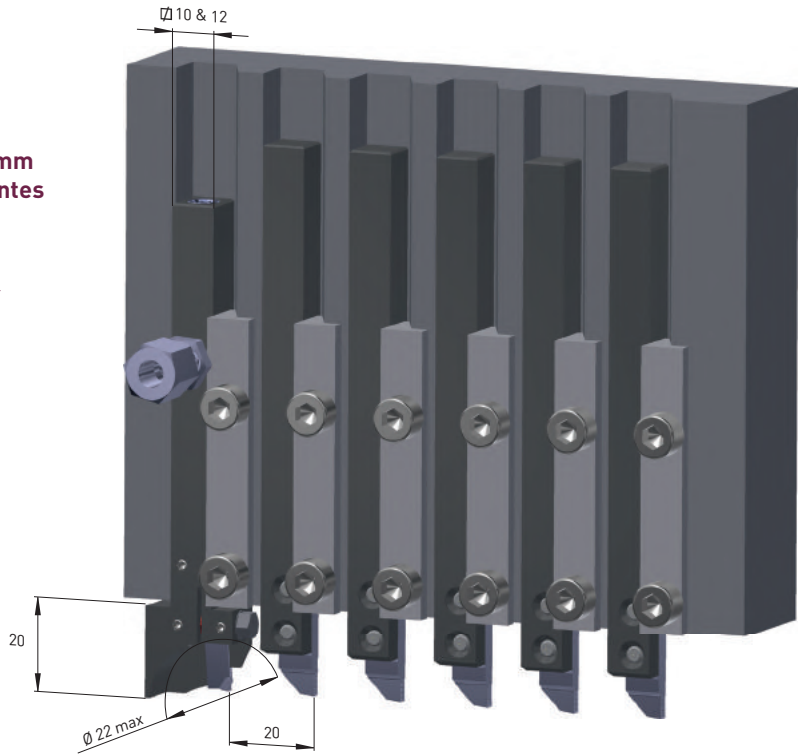

Facilité d'accès

Zugangseichtigkeit

Excellent accessibility

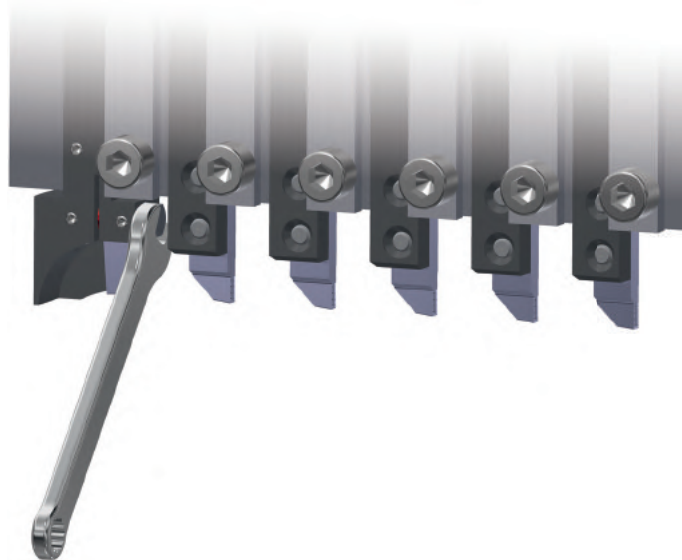

Changement de la plaquelette sans démontage

Veränderung der Platte ohne Zerlegung

Change of insert without disassembly

Butée de serrage
Spannungs-Anschlag
Clamping stop

Distance de serrage
 Anschlagabstand
 Distance clamping

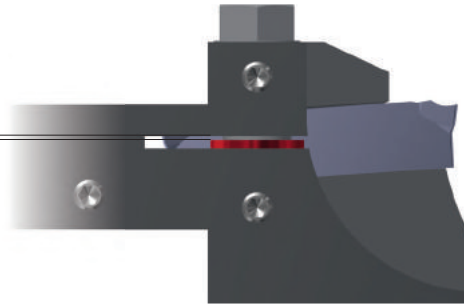

Recommendations de serrage:
 n'utiliser que la clé fournie
Spannungsempfehlungen:
 nur den gelieferten Schlüssel benutzen
Tightening recommendation:
 only use the delivered key

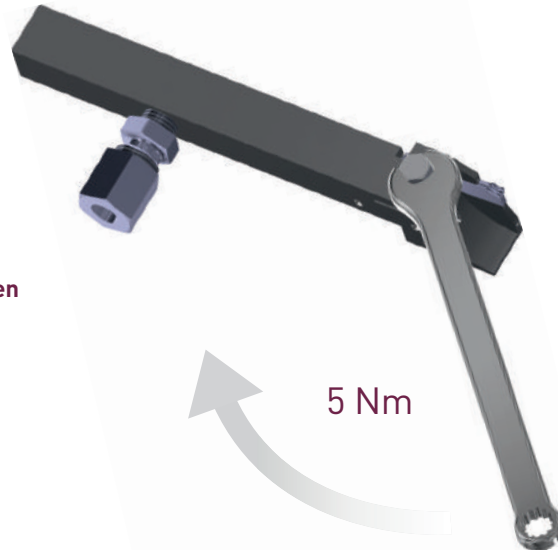

Support JET à double lubrification
JET Halter mit doppeltem Schmierung
Jet holder with double lubrication

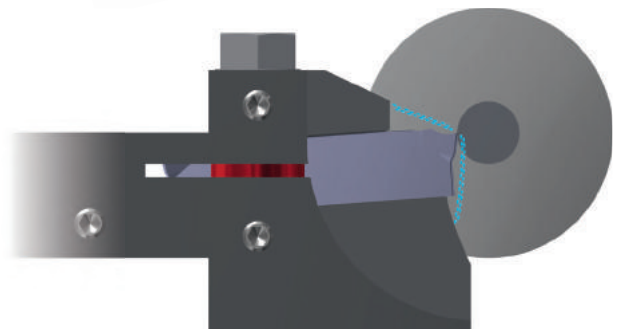

EVOCUT-LINE

Géométries de coupe

Spanformgeometrie

Cutting geometries

UN

UL
UR

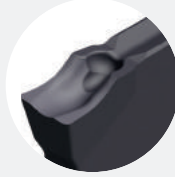

- géométrie positive universelle, faibles efforts de coupe
- bonne maîtrise du copeau
- 1^{er} choix pour l'inox

- allgemeine Geometrie, geringe Schnittkräfte
- gute Spankontrolle
- 1. Wahl für rostfreiem Stahl

- all-round geometry, low cutting forces
- efficient chip control
- 1st choice for stainless steel

JN

JR



- géométrie universelle
- excellent rétrécissement du copeau pour un meilleur contrôle
- conseillé pour le tronçonnage de pièces à parois minces
- pour acier et inox

- allgemeine Geometrie
- ausgezeichnete Spanversmalerung für eine bessere Spankontrolle
- für abstechen von dünnwandigen Teilen empfohlen
- für Stahl und rostfreiem Stahl

- all-round geometry
- very efficient arrow for a better chip control
- recommended for parting off of thin-walled parts
- for steel and stainless steel

TN

TR



- géométrie négative
- utilisation dans des conditions de rigidité optimale
- pour les matières à haute ténacité
- universel pour les aciers et inox

- negative Geometrie
- bei stabilen Verhältnissen einsetzbar
- für hohe widerstandsfähige Rohstoffe
- allgemein für Stahl und rostfreiem Stahl

- negative geometry
- use in solid cutting conditions
- for high toughness material
- universal for steel and stainless steel

AN

AR



- géométrie fortement positive
- roule-copeau poli avec arêtes de coupe vives
- 1^{er} choix pour aluminium et matériaux non ferreux

- stark positive Geometrie
- geschliffene Spanrolle mit scharfe Schneidkanten
- 1. Wahl für Aluminium und Nichteisenmetalle

- very positive geometry
- polished chip roller with sharp cutting edge
- 1st choice for aluminium and non-ferrous materials

Nuances

Sorten

Grades

<p>P M N S</p> <p>TiAlN revêtement PVD PVD Beschichtung PVD coating</p>	<p>P M <input type="checkbox"/> <input type="checkbox"/></p> <p>Tmax revêtement PVD PVD Beschichtung PVD coating</p>	<p>P M <input type="checkbox"/> <input type="checkbox"/></p> <p>Zmax revêtement PVD PVD Beschichtung PVD coating</p>
<ul style="list-style-type: none"> pour l'usinage des aciers, aciers inoxydables et alliages de titane 1^{er} choix pour les avances faibles à modérées 	<ul style="list-style-type: none"> nuance pour usinage moyen à lourd des aciers, aciers alliés et inoxydables bonne résistance aux températures d'usinage élevées 1^{er} choix pour le tronçonnage des aciers au carbone et des aciers fortement alliés 	<ul style="list-style-type: none"> pour l'usinage des aciers, aciers inoxydables et alliages de titane en conditions défavorables bonne résistance aux chocs à des vitesses de coupe moyenne à faible 1^{er} choix pour le tronçonnage en coupe interrompue
<ul style="list-style-type: none"> für die Bearbeitung von Stahl, rostfreiem Stahl und Titanlegierungen beste Wahl für niedrige bis mittlere Vorschübe 	<ul style="list-style-type: none"> Sorte für mittlere bis hohe Belastung in Stahl und legierter Stahlbearbeitung gute Bearbeitungswarmfestigkeit für die Bearbeitung von legiertem Kohlenstahl und hoch legiertem Stahl bestens geeignet 	<ul style="list-style-type: none"> für die Bearbeitung von Stahl, rostfreiem Stahl und Titanlegierungen in schwierige Bearbeitungsfälle gute Bruchfestigkeit mit durchschnittliche bis niedrige Schnittgeschwindigkeit für die Bearbeitung in unterbrochenen Schnitte bestens geeignet
<ul style="list-style-type: none"> for machining of steel, stainless steel and titanium alloys first choice for low to average cutting speed 	<ul style="list-style-type: none"> grade for medium to heavy machining of steel, stainless steel and alloyed steel high machining heat resistance first choice for the machining of carbon steel and high alloyed steel 	<ul style="list-style-type: none"> for machining of steel, stainless steel and titanium alloys in unfavourable machining conditions good impact resistance with average to low cutting speed first choice for machining in interrupted cut
<p>P M <input type="checkbox"/> <input type="checkbox"/></p> <p>ZTi6 revêtement CVD CVD Beschichtung CVD coating</p>	<p><input type="checkbox"/> <input type="checkbox"/> N S</p> <p>AS revêtement PVD PVD Beschichtung PVD coating</p>	<p><input type="checkbox"/> <input type="checkbox"/> N S</p> <p>N non-revêtu unbeschichtet uncoated</p>
<ul style="list-style-type: none"> nuance très tenace grande résistance à la température 1^{er} choix pour les aciers «haute température» secondairement pour les aciers inox 	<ul style="list-style-type: none"> nuance pour métaux non ferreux très faible coefficient de frottement 1^{er} choix pour l'usinage des aluminiums jusqu'à 5% Si, des cuivres et titanes faiblement alliés 	<ul style="list-style-type: none"> nuance non revêtu recommandé pour l'usinage des matières non-ferreuses titane, laiton, cuivre, aluminium sans silicium, plastique
<ul style="list-style-type: none"> sehr zähe Sorte hohe Bearbeitungswarmfestigkeit 1. Wahl für „hohe Temperatur“ Stähle sekundär für rostfreie Stähle 	<ul style="list-style-type: none"> Sorte für Nichteisenmetalle sehr geringer Reibwert für die Bearbeitung von Aluminium bis 5% Si, Kupfer und niedriglegiertem Titan bestens geeignet 	<ul style="list-style-type: none"> unbeschichtete Sorte für die Bearbeitung von Nichteisenmetalle empfohlen Titan, Messing, Kupfer, Silicium freies Aluminium, Kunststoff
<ul style="list-style-type: none"> very strong grade good wear resistance 1st choice for "high temperature" steels secondarily for stainless steels 	<ul style="list-style-type: none"> grade for non-ferrous materials very low friction ratio first choice for aluminium up to 5% Si, copper and low alloyed titanium 	<ul style="list-style-type: none"> uncoated grade recommended for machining of non-ferrous materials titanium, brass, bronze, aluminium without silicium, plastic

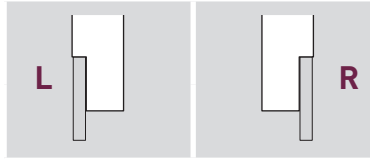
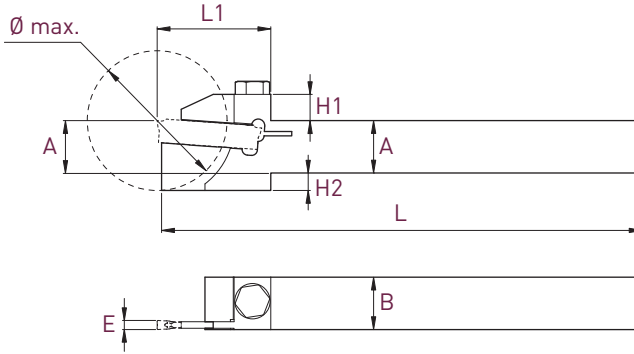

Plaquettes WSP Inserts	A x B	L	Ø max.	L1	H1	H2	Art. N°		Pièces de rechange Ersatzteile Spare parts	
							Art. N°	Art. N°	Art. N°	Art. N°
E 1.5	10x12	110	22	20	5	6	ET15-H1012L-D22	ET15-H1012R-D22	V-M5X20-6P6	C-6PEX-6.0
	12x12	110	22	20	5	4	ET15-H1212L-D22	ET15-H1212R-D22		
	12.7x12.7	110	22	20	5	3	ET15-H12.7L-D22	ET15-H12.7R-D22		
Type ET15	12x12	110	32	26	6	4	ET15-H1212L-D32	ET15-H1212R-D32	V-M5X21-6P7	C-6PEX-7.0
	12.7x12.7	110	32	26	6	3	ET15-H12.7L-D32	ET15-H12.7R-D32		
	16x16	110	32	26	6	-	ET15-H1616L-D32	ET15-H1616R-D32		
E 2.0	10x12	110	22	20	5	6	ET20-H1012L-D22	ET20-H1012R-D22	V-M5X20-6P6	C-6PEX-6.0
	12x12	110	22	20	5	4	ET20-H1212L-D22	ET20-H1212R-D22		
	12.7x12.7	110	22	20	5	3	ET20-H12.7L-D22	ET20-H12.7R-D22		
Type ET20	12x12	110	32	26	6	4	ET20-H1212L-D32	ET20-H1212R-D32	V-M5X21-6P7	C-6PEX-7.0
	12.7x12.7	110	32	26	6	3	ET20-H12.7L-D32	ET20-H12.7R-D32		
	16x16	110	32	26	6	-	ET20-H1616L-D32	ET20-H1616R-D32		
E 2.5	10x12	110	22	20	5	6	ET25-H1012L-D22	ET25-H1012R-D22	V-M5X20-6P6	C-6PEX-6.0
	12x12	110	22	20	5	4	ET25-H1212L-D22	ET25-H1212R-D22		
	12.7x12.7	110	22	20	5	3	ET25-H12.7L-D22	ET25-H12.7R-D22		
Type ET25	12x12	110	32	26	6	4	ET25-H1212L-D32	ET25-H1212R-D32	V-M5X21-6P7	C-6PEX-7.0
	12.7x12.7	110	32	26	6	3	ET25-H12.7L-D32	ET25-H12.7R-D32		
	16x16	110	32	26	6	-	ET25-H1616L-D32	ET25-H1616R-D32		
E 3.0	16x16	130	44	35	8	4	ET30-H1616L-D44	ET30-H1616R-D44	V-M5X27-6P7	C-6PEX-7.0
	20x20	130	44	35	8	-	ET30-H2020L-D44	ET30-H2020R-D44		
	25x25	140	44	35	8	-	ET30-H2525L-D44	ET30-H2525R-D44		

* livré avec chaque porte-outil
mit jedem Halter geliefert
delivered with each holder

Porte-outils avec arrosage intégré
 Halter mit integrierter Kühlmittelzufuhr
 Holders with integrated coolant supply

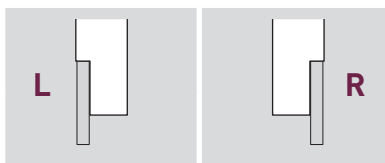
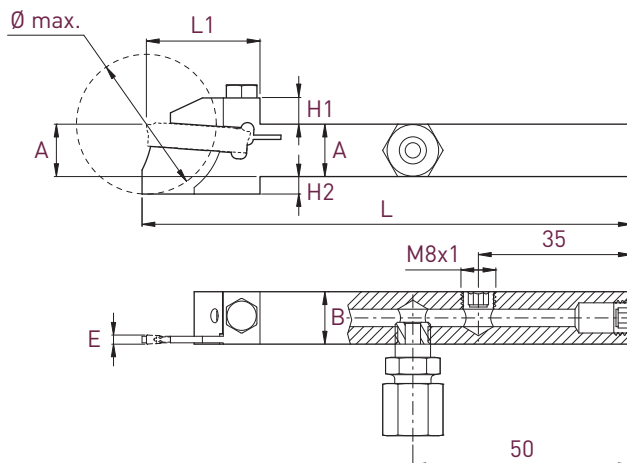

∅ max 44 mm

H JET Series

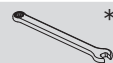

Plaquettes WSP Inserts	A x B	L	∅ max.	L1	H1	H2	Art. N°	
							Art. N°	Art. N°
E 2.0 Type ET20	10x12	110	22	20	5	6	ET20-H1012L-JET22	ET20-H1012R-JET22
	12x12	110	22	20	5	4	ET20-H1212L-JET22	ET20-H1212R-JET22
	12.7x12.7	110	22	20	5	3	ET20-H12.7L-JET22	ET20-H12.7R-JET22
	12x12	110	32	26	6	4	ET20-H1212L-JET32	ET20-H1212R-JET32
	12.7x12.7	110	32	26	6	3	ET20-H12.7L-JET32	ET20-H12.7R-JET32
	16x16	110	32	26	6	-	ET20-H1616L-JET32	ET20-H1616R-JET32
E 2.5 Type ET25	16x16	130	44	35	8	4	ET20-H1616L-JET44	ET20-H1616R-JET44
	20x20	130	44	35	8	-	ET20-H2020L-JET44	ET20-H2020R-JET44
	10x12	110	22	20	5	6	ET25-H1012L-JET22	ET25-H1012R-JET22
	12x12	110	22	20	5	4	ET25-H1212L-JET22	ET25-H1212R-JET22
	12.7x12.7	110	22	20	5	3	ET25-H12.7L-JET22	ET25-H12.7R-JET22
	12x12	110	32	26	6	4	ET25-H1212L-JET32	ET25-H1212R-JET32
E 3.0 Type ET30	12.7x12.7	110	32	26	6	3	ET25-H12.7L-JET32	ET25-H12.7R-JET32
	16x16	110	32	26	6	-	ET25-H1616L-JET32	ET25-H1616R-JET32
	16x16	130	44	35	8	4	ET25-H1616L-JET44	ET25-H1616R-JET44
	20x20	130	44	35	8	-	ET25-H2020L-JET44	ET25-H2020R-JET44
	16x16	110	32	26	6	-	ET30-H1616L-JET32	ET30-H1616R-JET32
	16x16	130	44	35	8	4	ET30-H1616L-JET44	ET30-H1616R-JET44
20x20	130	44	35	8	-	ET30-H2020L-JET44	ET30-H2020R-JET44	
25x25	140	44	35	8	-	ET30-H2525L-JET44	ET30-H2525R-JET44	

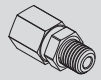
Pièces de rechange Ersatzteile Spare parts	
 *	 *
Art. N°	Art. N°
V-M5X20-6P6-J	C-6PEX-6.0
V-M5X21-6P7-J	C-6PEX-7.0
V-M5X27-6P7-J	C-6PEX-7.0
V-M5X20-6P6-J	C-6PEX-6.0
V-M5X21-6P7-J	C-6PEX-7.0
V-M5X27-6P7-J	C-6PEX-7.0
V-M5X21-6P7-J	C-6PEX-7.0
V-M5X27-6P7-J	C-6PEX-7.0

Pièces de rechange Ersatzteile Spare parts		
	Art. N°	Art. N°
	J-M8X1-D6	JB-M8X1

* Livré avec chaque porte-outil
 mit jedem Halter geliefert
 delivered with each holder

EVOCUT-LINE

Porte-lames avec arrosage

Halter für Stechklinge mit Kühlung

Holder for parting-off blades with coolant

H-HM-JET Series

new

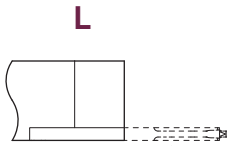
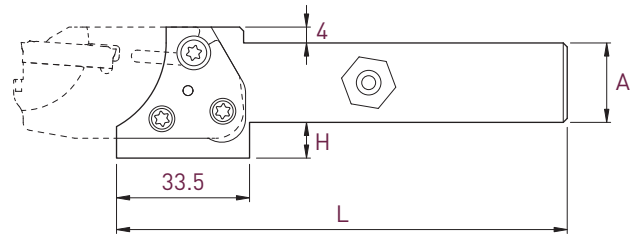

HM-IN (p. 8.14)
HM-IL-JET (p. 8.15)

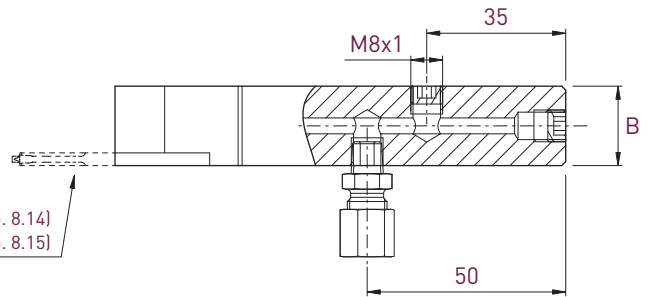

HM-IN (p. 8.14)
HM-IR-JET (p. 8.15)



A x B	L	H	Art. N°	Art. N°
16x16	113.5	13	H1616L-HM-JET	H1616R-HM-JET
20x20	113.5	9	H2020L-HM-JET	H2020R-HM-JET
25x25	138.5	4	H2525L-HM-JET	H2525R-HM-JET

Pièces de rechange Ersatzteile Spare parts					
	Art. N°	Art. N°	Art. N°	Art. N°	Art. N°
	V-M5X10-T20IP	V-M6X10-T20IP	J-M8X1-D6	JB-M8X1	C-T20IP

new

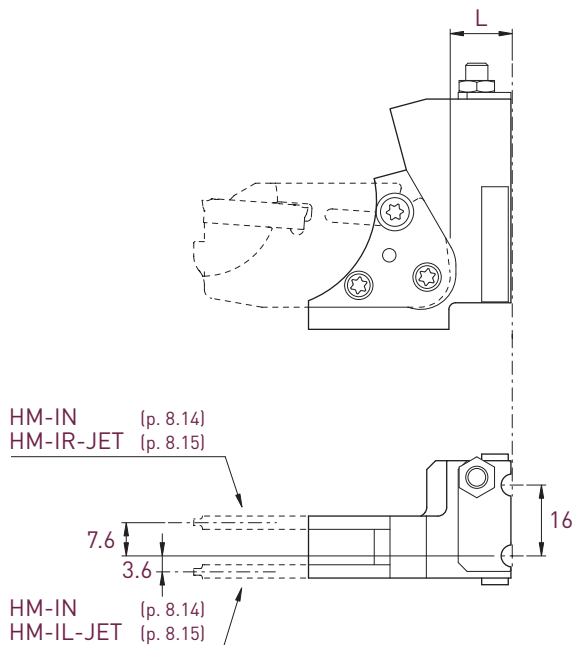

Pièces de rechange
Ersatzteile
Spare parts



Interface	Machine compatibility	L	Art. N°	Art. N°	Art. N°	Art. N°
GWS02	AS14	14	GWS02R-02001-HM-JET	V-M5X10-T20IP	V-M6X10-T20IP	C-T20IP
	SAS16					
	SBS20					
	Others	22	GWS02R-02002-HM-JET			

new

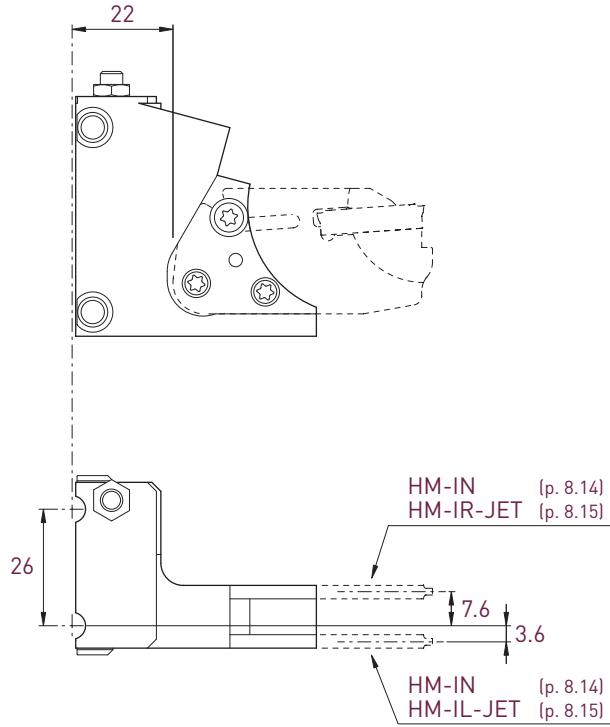

Pièces de rechange
Ersatzteile
Spare parts

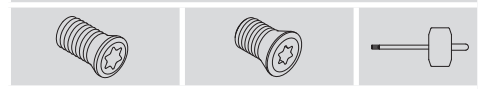

Interface	Machine compatibility	Art. N°	Art. N°	Art. N°	Art. N°
GWS41	MultiSwiss 6X16	GWS41L-41001-HM-JET	V-M5X10-T20IP	V-M6X10-T20IP	C-T20IP
	MultiDeco 20X6				
	MultiDeco 20X8				
	MultiDeco 26X6				
	MultiDeco 32X6				
	MultiAlpha 20X8				
	MultiSigma 24X8				

new

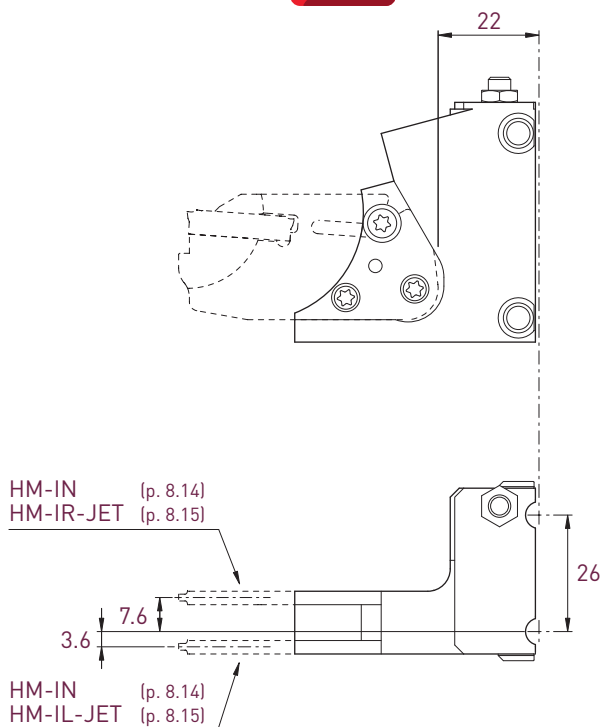



Pièces de rechange
Ersatzteile
Spare parts

Interface	Machine compatibility	Art. N°	Pièces de rechange Ersatzteile Spare parts		
			Art. N°	Art. N°	Art. N°
GWS41	MultiSwiss 6X16	GWS41R-41001-HM-JET	V-M5X10-T20IP	V-M6X10-T20IP	C-T20IP
	MultiDeco 20X6				
	MultiDeco 20X8				
	MultiDeco 26X6				
	MultiDeco 32X6				
	MultiAlpha 20X8				
	MultiSigma 24X8				

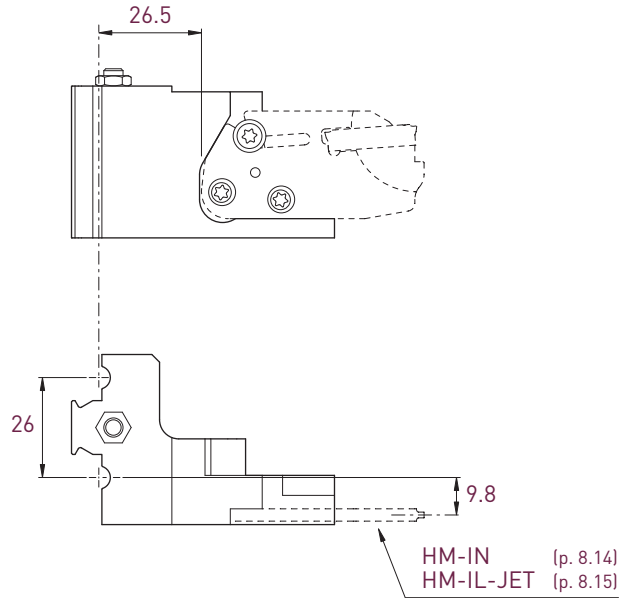
new

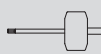

		Pièces de rechange Ersatzteile Spare parts			
Interface	Machine compatibility	Art. N°	 Art. N°	 Art. N°	 Art. N°
GWS202	MultiSwiss 6X32	GWS202L-202001-HM-JET	V-M5X10-T20IP	V-M6X10-T20IP	C-T20IP
	MultiSwiss 8X26				

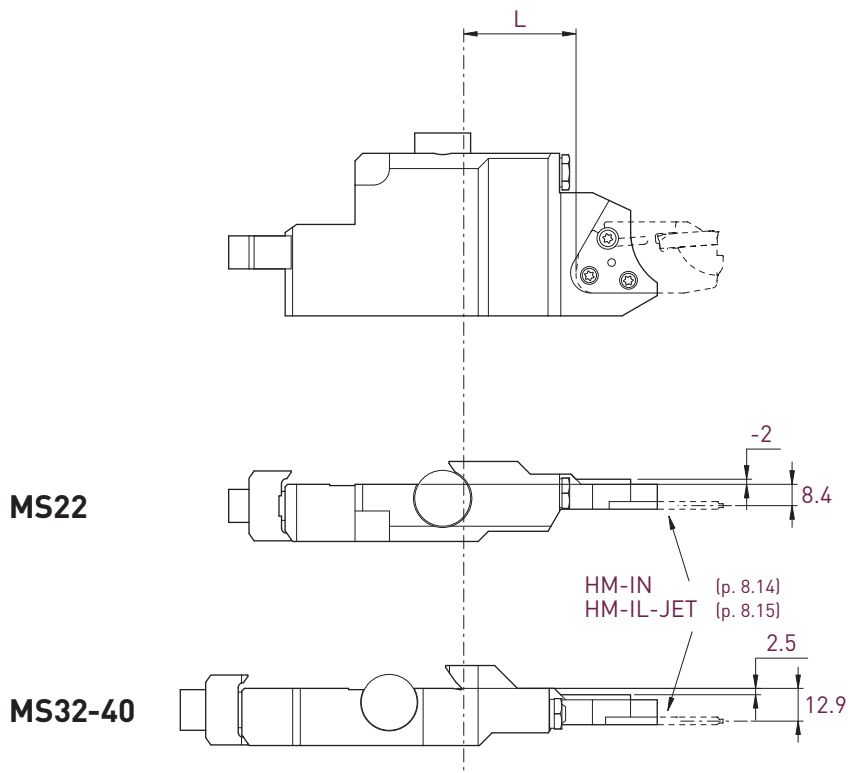

new



MS22

MS32-40

Pièces de rechange
Ersatzteile
Spare parts

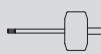
Machine compatibility	L	Art. N°	Pièces de rechange Ersatzteile Spare parts		
			Art. N°	Art. N°	Art. N°
MS22	44.2	MS22-W5190231-HM-JET			
MS32-40	45.5	MS32-40-W5190233-HM-JET	V-M5X10-T20IP	V-M6X10-T20IP	C-T20IP

EVO CUT-LINE

Lames pour système modulaire
 Stechklinge für modulares System
 Parting-off blades for modular system

HM Series

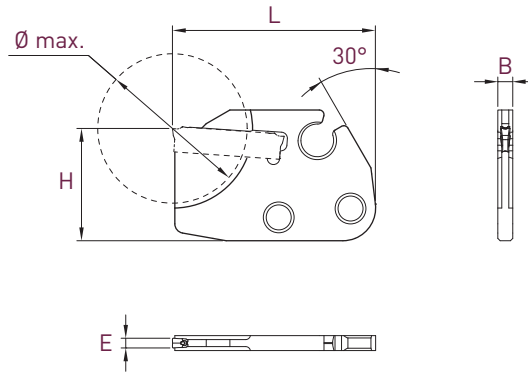

N

Plaquettes WSP Inserts	Ø max.	B	L	H	Art. N°
E 1.5 Type ET15	20	3.2	43.5	24	ET15-HM-IN-43-D20
	32	3.2	43.5	24	ET15-HM-IN-43-D32
E 2.0 Type ET20	20	3.2	43.5	24	ET20-HM-IN-43-D20
	26	3.2	43.5	24	ET20-HM-IN-43-D26
	26	3.2	54	24	ET20-HM-IN-54-D26
	32	3.2	43.5	24	ET20-HM-IN-43-D32
E 3.0 Type ET30	32	3.2	43.5	24	ET30-HM-IN-43-D32

Lames avec arrosage intégré

Stechklinge mit integrierter Kühlmittelzufuhr

Parting-off blades with integrated coolant supply

HM-JET Series

new

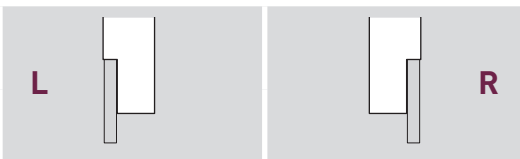
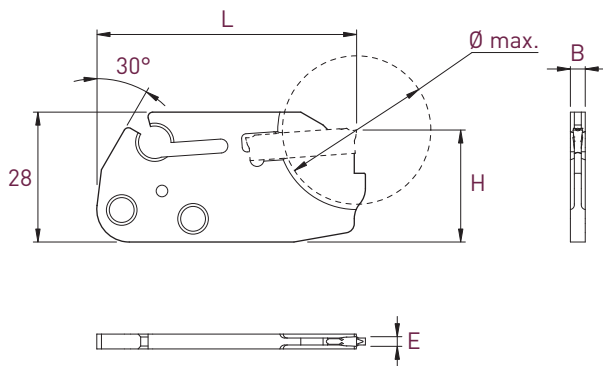

Plaquettes WSP Inserts	Ø max.	B	L	H	Art. N°	Art. N°
E 2.0 Type ET20	20	3.2	48.5	24	ET20-HM-IL-48.5-JET20	ET20-HM-IR-48.5-JET20
	24		48.5		ET20-HM-IL-48.5-JET24	ET20-HM-IR-48.5-JET24
	32		45.5		ET20-HM-IL-45.5-JET32	ET20-HM-IR-45.5-JET32
	32		56		ET20-HM-IL-56-JET32	ET20-HM-IR-56-JET32
	42		48.5		ET20-HM-IL-48.5-JET42	ET20-HM-IR-48.5-JET42
E 3.0 Type ET30	32	3.2	45.5	24	ET30-HM-IL-45.5-JET32	ET30-HM-IR-45.5-JET32
	44		48.5		ET30-HM-IL-48.5-JET42	ET30-HM-IR-48.5-JET42

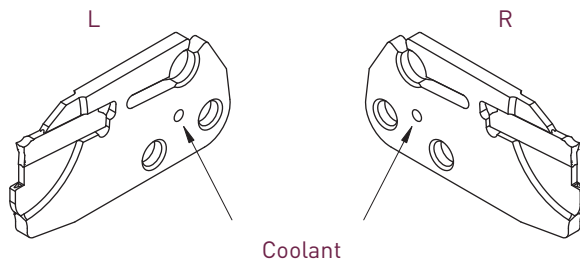

EVOCUT-LINE

Lames de tronçonnage

Stechklinge

Parting-off blades

HK Series

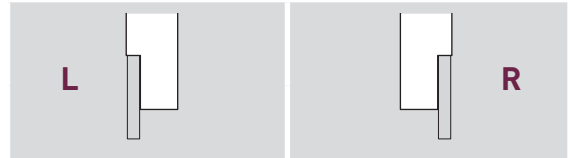
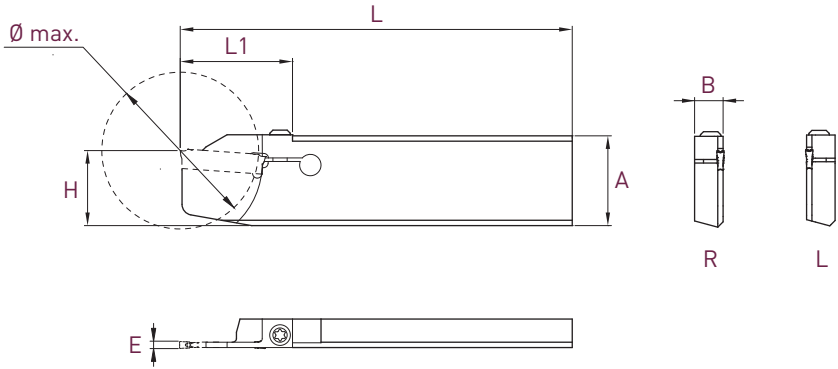

Plaquettes WSP Inserts	A x B	L	Ø max.	L1	H	Art. N°	Art. N°
E 1.5 Type ET15	26x8	110	20	19.5	21	ET15-HK-2608L-110-D20	ET15-HK-2608R-110-D20
	26x8	110	32	25.5	21	ET15-HK-2608L-110-D32	ET15-HK-2608R-110-D32
E 2.0 Type ET20	26x8	110	32	25.5	21	ET20-HK-2608L-110-D32	ET20-HK-2608R-110-D32
	26x8	110	44	31.5	21	ET20-HK-2608L-110-D44	ET20-HK-2608R-110-D44

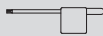
Pièces de rechange Ersatzteile Spare parts	 *	 *
	Art. N°	Art. N°
	V-M4X14.5-T15-EVOCUT	C-T15

* livré avec chaque lame
mit jedem Stechkling geliefert
delivered with each blade

Lames de tronçonnage avec dégagement pour accès contre-broche



Stecklinge mit Aussparung für Gegenspindel Zugriff

Parting-off blades with recess for subspindle access

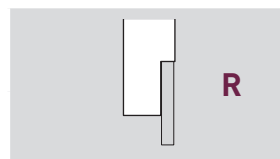
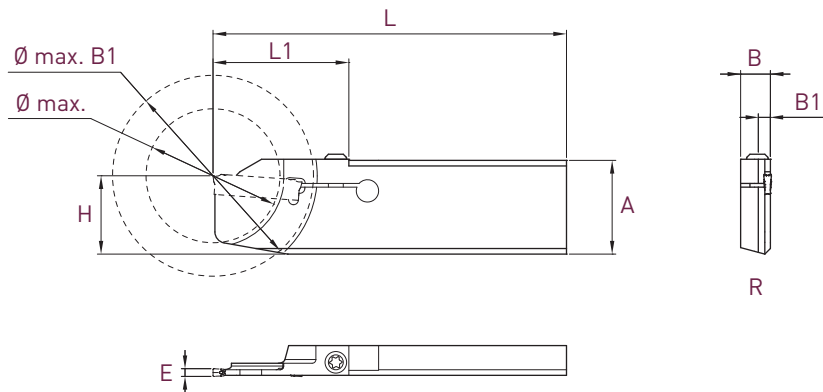
HK-RS Series



Plaquettes WSP Inserts	A x B	L	Ø max.	Ø max. B1	B1	L1	H	Art. N°
E 1.5 Type ET15	26x8	95	36	54	3.25	36.5	21	ET15-HK-2608RS-95-D36
E 2.0 Type ET20	26x8	95	36	54	3.25	36.5	21	ET20-HK-2608RS-95-D36

Pièces de rechange Ersatzteile Spare parts	 *	 *
	Art. N°	Art. N°
	V-M4X14.5-T15-EVOCUT	C-T15

* livré avec chaque lame
mit jedem Steckling geliefert
delivered with each blade

EVOCUT-LINE

Lames de tronçonnage inversées
 Überkopf Stechklinge
 Upside down parting-off blades

HUK Series

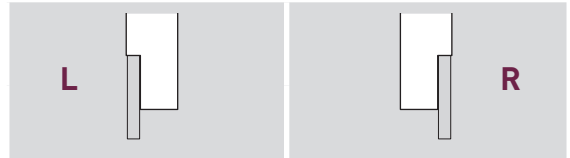
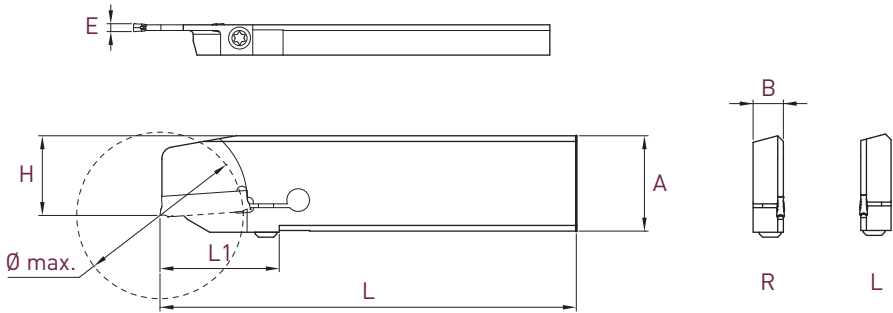

Plaquettes WSP Inserts	A x B	L	Ø max.	L1	H	Art. N°	Art. N°
E 1.5 Type ET15	26x8	110	20	19.5	21	ET15-HUK-2608L-110-D20	ET15-HUK-2608R-110-D20
	26x8	110	32	25.5	21	ET15-HUK-2608L-110-D32	ET15-HUK-2608R-110-D32
E 2.0 Type ET20	26x8	110	32	25.5	21	ET20-HUK-2608L-110-D32	ET20-HUK-2608R-110-D32
	26x8	110	44	31.5	21	ET20-HUK-2608L-110-D44	ET20-HUK-2608R-110-D44

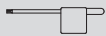
Pièces de rechange Ersatzteile Spare parts	 *	 *
	Art. N°	Art. N°
	V-M4X14.5-T15-EVOCUT	C-T15

* livré avec chaque lame
 mit jedem Steckling geliefert
 delivered with each blade

EVOCUT-LINE

Plaquettes de tronçonnage
 Abstechwendeplatten
 Cut off inserts

UN Series

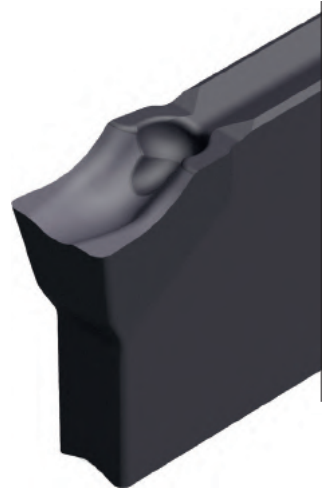
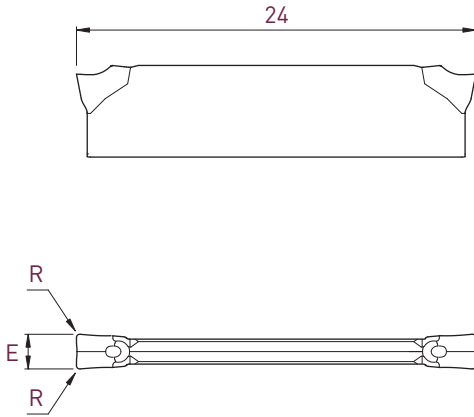

			UN				
Type	$E_{\pm 0.05}$	R	Art. N°	T:AIN	Tmax	Zmax	ZTi6
ET15	1.35	0	ET15-UN-000F	<input checked="" type="checkbox"/>	<input type="checkbox"/>	<input type="checkbox"/>	<input type="checkbox"/>
	1.5	0.2	ET15-UN-002	<input checked="" type="checkbox"/>	<input checked="" type="checkbox"/>	<input checked="" type="checkbox"/>	<input type="checkbox"/>
ET20	1.85	0	ET20-UN-000F	<input checked="" type="checkbox"/>	<input type="checkbox"/>	<input type="checkbox"/>	<input type="checkbox"/>
	2.0	0.2	ET20-UN-002	<input checked="" type="checkbox"/>	<input checked="" type="checkbox"/>	<input checked="" type="checkbox"/>	<input checked="" type="checkbox"/>
ET25	2.35	0	ET25-UN-000F	<input checked="" type="checkbox"/>	<input type="checkbox"/>	<input type="checkbox"/>	<input type="checkbox"/>
	2.5	0.3	ET25-UN-003	<input checked="" type="checkbox"/>	<input checked="" type="checkbox"/>	<input checked="" type="checkbox"/>	<input checked="" type="checkbox"/>
ET30	2.85	0	ET30-UN-000F	<input checked="" type="checkbox"/>	<input type="checkbox"/>	<input type="checkbox"/>	<input type="checkbox"/>
	3.0	0.3	ET30-UN-003	<input checked="" type="checkbox"/>	<input checked="" type="checkbox"/>	<input checked="" type="checkbox"/>	<input checked="" type="checkbox"/>

Plaquettes de tronçonnage

Abstechwendeplatten

Cut off inserts

UL-UR Series

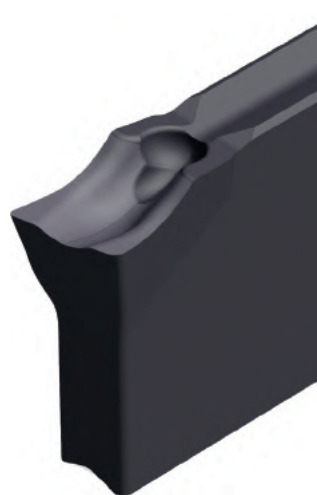
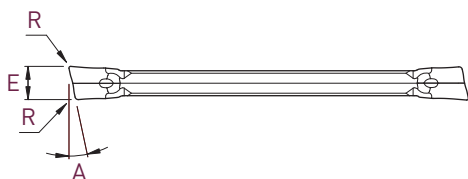
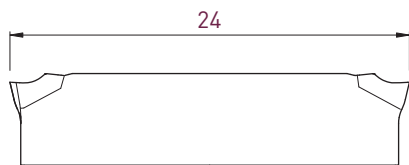

Type	E ±0.05	A	R	UL			UR				
				Art. N°	TiAIN	Tmax	Zmax	Art. N°	TiAIN	Tmax	Zmax
ET15	1.5	6°	0.2	-	<input type="checkbox"/>	<input type="checkbox"/>	<input type="checkbox"/>	ET15-UR-602	<input type="checkbox"/>	<input type="checkbox"/>	<input type="checkbox"/>
	1.35	8°	0	-	<input type="checkbox"/>	<input type="checkbox"/>	<input type="checkbox"/>	ET15-UR-800F	<input type="checkbox"/>	<input type="checkbox"/>	<input type="checkbox"/>
	1.5	12°	0.1	-	<input type="checkbox"/>	<input type="checkbox"/>	<input type="checkbox"/>	ET15-UR-1201	<input type="checkbox"/>	<input type="checkbox"/>	<input type="checkbox"/>
	1.35	15°	0	ET15-UL-1500F	<input checked="" type="checkbox"/>	<input type="checkbox"/>	<input type="checkbox"/>	ET15-UR-1500F	<input type="checkbox"/>	<input type="checkbox"/>	<input type="checkbox"/>
ET20	2.0	6°	0.2	-	<input type="checkbox"/>	<input type="checkbox"/>	<input type="checkbox"/>	ET20-UR-602	<input type="checkbox"/>	<input type="checkbox"/>	<input type="checkbox"/>
	1.85	8°	0	-	<input type="checkbox"/>	<input type="checkbox"/>	<input type="checkbox"/>	ET20-UR-800F	<input type="checkbox"/>	<input type="checkbox"/>	<input type="checkbox"/>
	2.0	12°	0.1	-	<input type="checkbox"/>	<input type="checkbox"/>	<input type="checkbox"/>	ET20-UR-1201	<input type="checkbox"/>	<input type="checkbox"/>	<input type="checkbox"/>
	1.85	15°	0	ET20-UL-1500F	<input checked="" type="checkbox"/>	<input type="checkbox"/>	<input type="checkbox"/>	ET20-UR-1500F	<input type="checkbox"/>	<input type="checkbox"/>	<input type="checkbox"/>
ET25	2.5	6°	0.2	-	<input type="checkbox"/>	<input type="checkbox"/>	<input type="checkbox"/>	ET25-UR-602	<input type="checkbox"/>	<input type="checkbox"/>	<input type="checkbox"/>
	2.35	8°	0	-	<input type="checkbox"/>	<input type="checkbox"/>	<input type="checkbox"/>	ET25-UR-800F	<input type="checkbox"/>	<input type="checkbox"/>	<input type="checkbox"/>
	2.5	12°	0.1	-	<input type="checkbox"/>	<input type="checkbox"/>	<input type="checkbox"/>	ET25-UR-1201	<input type="checkbox"/>	<input type="checkbox"/>	<input type="checkbox"/>
	2.35	15°	0	ET25-UL-1500F	<input checked="" type="checkbox"/>	<input type="checkbox"/>	<input type="checkbox"/>	ET25-UR-1500F	<input type="checkbox"/>	<input type="checkbox"/>	<input type="checkbox"/>
ET30	3.0	6°	0.3	-	<input type="checkbox"/>	<input type="checkbox"/>	<input type="checkbox"/>	ET30-UR-603	<input type="checkbox"/>	<input type="checkbox"/>	<input type="checkbox"/>
	2.85	8°	0	-	<input type="checkbox"/>	<input type="checkbox"/>	<input type="checkbox"/>	ET30-UR-800F	<input type="checkbox"/>	<input type="checkbox"/>	<input type="checkbox"/>
	3.0	12°	0.2	-	<input type="checkbox"/>	<input type="checkbox"/>	<input type="checkbox"/>	ET30-UR-1202	<input type="checkbox"/>	<input type="checkbox"/>	<input type="checkbox"/>
	2.85	15°	0	ET30-UL-1500F	<input checked="" type="checkbox"/>	<input type="checkbox"/>	<input type="checkbox"/>	ET30-UR-1500F	<input type="checkbox"/>	<input type="checkbox"/>	<input type="checkbox"/>

EVOCUT-LINE









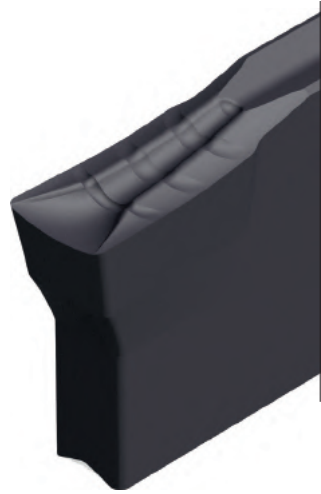
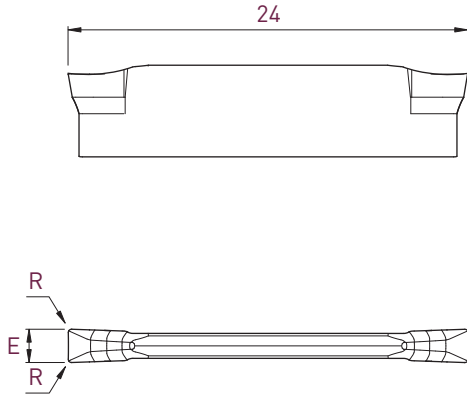

Plaquettes de tronçonnage

Abstechwendeplatten

Cut off inserts

JN Series



			JN				
							
Type	E ±0.05	R	Art. N°	    TiAlN	  Tmax	  Zmax	  ZTi6
ET15	1.5	0.2	ET15-JN-002	■ ■ ■	■ ■ ■ ■	■ ■ ■ ■	■ ■ ■ ■
ET20	2.0	0.2	ET20-JN-002	■ ■ ■ ■	■ ■ ■ ■	■ ■ ■ ■	■ ■ ■ ■
ET25	2.5	0.3	ET25-JN-003	■ ■ ■ ■	■ ■ ■ ■	■ ■ ■ ■	■ ■ ■ ■
ET30	3.0	0.3	ET30-JN-003	■ ■ ■ ■	■ ■ ■ ■	■ ■ ■ ■	■ ■ ■ ■

Plaquettes de tronçonnage

Abstechwendeplatten

Cut off inserts

JR Series

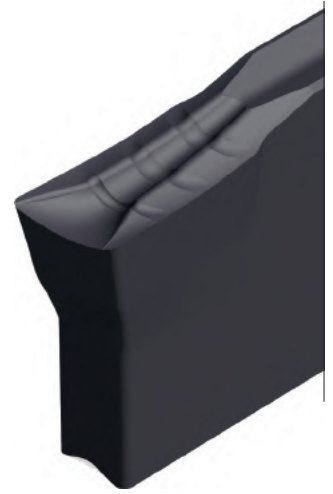
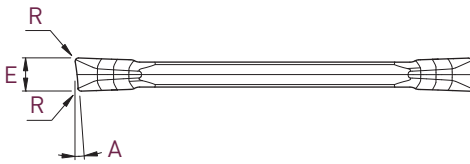
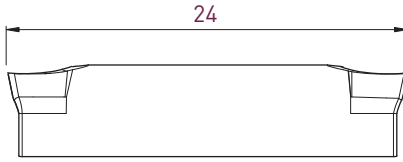

				JR			
Type	E ± 0.05	A	R	Art. N°	TiAlN	Tmax	Zmax
ET15	1.5	6°	0.2	ET15-JR-602	■	■	■
ET20	2.0	6°	0.2	ET20-JR-602	■	■	■
ET25	2.5	6°	0.2	ET25-JR-602	■	■	■
ET30	3.0	6°	0.3	ET30-JR-603	■	■	■

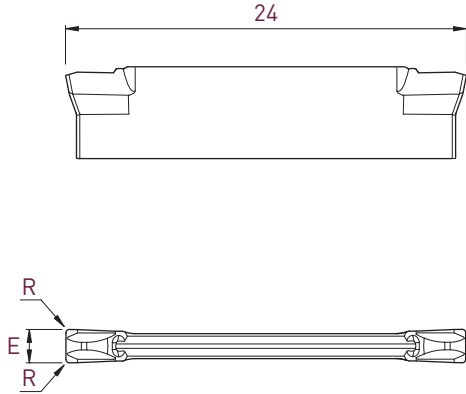

			TN 			
Type	E ±0.05	R	Art. N°	<input type="checkbox"/> P <input checked="" type="checkbox"/> N <input type="checkbox"/> TiAlN	<input type="checkbox"/> P <input checked="" type="checkbox"/> M <input type="checkbox"/> Zmax	<input type="checkbox"/> P <input checked="" type="checkbox"/> M <input type="checkbox"/> ZTi6
ET20	2.0	0.2	ET20-TN-002	■	■	■
ET25	2.5	0.3	ET25-TN-003	■	■	■
ET30	3.0	0.3	ET30-TN-003	■	■	■

Plaquettes de tronçonnage

Abstechwendeplatten

Cut off inserts

Negative geometry

TR Series

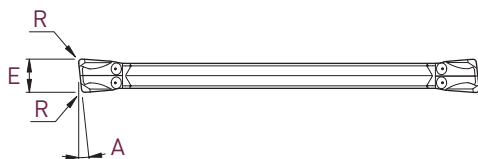
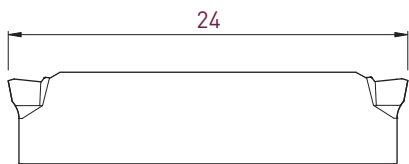

				TR																	
Type	E ±0.05	A	R	Art. N°	<table border="1"> <tr> <td><input type="checkbox"/></td><td><input type="checkbox"/></td><td><input type="checkbox"/></td><td><input type="checkbox"/></td> </tr> <tr> <td><input type="checkbox"/></td><td><input type="checkbox"/></td><td><input type="checkbox"/></td><td><input type="checkbox"/></td> </tr> <tr> <td><input type="checkbox"/></td><td><input type="checkbox"/></td><td><input type="checkbox"/></td><td><input type="checkbox"/></td> </tr> <tr> <td><input type="checkbox"/></td><td><input type="checkbox"/></td><td><input type="checkbox"/></td><td><input type="checkbox"/></td> </tr> </table>	<input type="checkbox"/>	<input type="checkbox"/>	<input type="checkbox"/>	<input type="checkbox"/>	<input type="checkbox"/>	<input type="checkbox"/>	<input type="checkbox"/>	<input type="checkbox"/>	<input type="checkbox"/>	<input type="checkbox"/>	<input type="checkbox"/>	<input type="checkbox"/>	<input type="checkbox"/>	<input type="checkbox"/>	<input type="checkbox"/>	<input type="checkbox"/>
<input type="checkbox"/>	<input type="checkbox"/>	<input type="checkbox"/>	<input type="checkbox"/>																		
<input type="checkbox"/>	<input type="checkbox"/>	<input type="checkbox"/>	<input type="checkbox"/>																		
<input type="checkbox"/>	<input type="checkbox"/>	<input type="checkbox"/>	<input type="checkbox"/>																		
<input type="checkbox"/>	<input type="checkbox"/>	<input type="checkbox"/>	<input type="checkbox"/>																		
ET20	2.0	6°	0.2	ET20-TR-602	■ ■ ■																
ET25	2.5	6°	0.2	ET25-TR-602	■ ■ ■																
ET30	3.0	6°	0.3	ET30-TR-603	■ ■ ■ ■																

EVOCUT-LINE

Plaquettes de tronçonnage

Abstechwendeplatten

Cut off inserts

AN Series

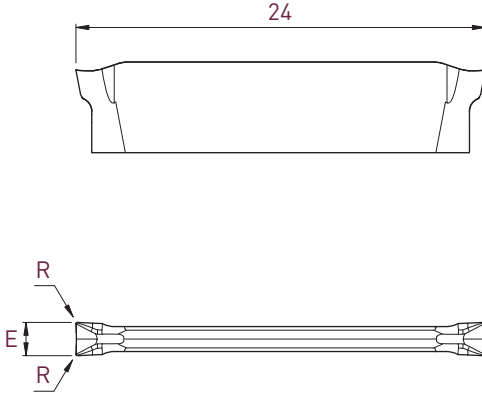

			AN			
Type	E ± 0.05	R	Art. N°	T	A	N
ET20	2.0	0.2	ET20-AN-002F	<input checked="" type="checkbox"/>	<input checked="" type="checkbox"/>	<input checked="" type="checkbox"/>
ET30	3.0	0.3	ET30-AN-003F	<input checked="" type="checkbox"/>	<input checked="" type="checkbox"/>	<input checked="" type="checkbox"/>

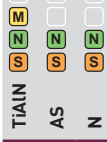

Plaquettes de tronçonnage

Abstechwendeplatten

Cut off inserts

AR Series

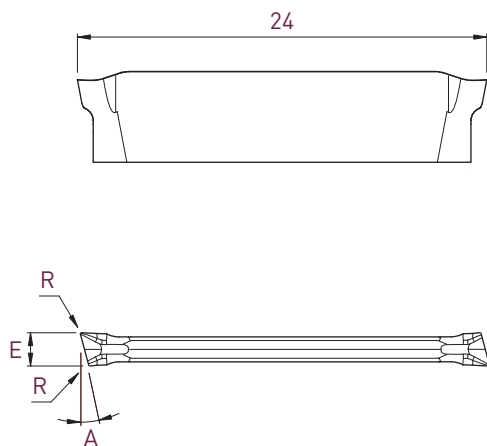









				AR			
Type	E ± 0.05	A	R	Art. N°	TiAIN	AS	N
ET20	2.0	15°	0.1	ET20-AR-1501F	<input checked="" type="checkbox"/> M <input checked="" type="checkbox"/> N <input checked="" type="checkbox"/> S	<input type="checkbox"/> <input checked="" type="checkbox"/> N <input checked="" type="checkbox"/> S	<input type="checkbox"/> <input checked="" type="checkbox"/> N <input checked="" type="checkbox"/> S
ET30	3.0	15°	0.2	ET30-AR-1502F	<input type="checkbox"/> <input checked="" type="checkbox"/> N <input checked="" type="checkbox"/> S	<input type="checkbox"/> <input checked="" type="checkbox"/> N <input checked="" type="checkbox"/> S	<input type="checkbox"/> <input checked="" type="checkbox"/> N <input checked="" type="checkbox"/> S

EVOCUT-LINE

Paramètres de coupe indicatifs

Empfohlene Schnittwerte

Standard machining data

						Acier Stahl Steel						Inox Rostfreistahl Stainless steel		
		ET15	ET20	ET25	ET30	Acier de décolletage Automatenstahl Free-cutting steel		Acier faiblement allié Leicht legierter Stahl Low alloyed steel		Acier fortement allié Legierter Stahl High alloyed steel		Austenitique et martensitique Austenitic and martensitic		
		VC (m/min)	F (mm/U)	VC (m/min)	F (mm/U)	VC (m/min)	F (mm/U)	VC (m/min)	F (mm/U)	VC (m/min)	F (mm/U)			
Avance standard Standard Vorschub Standard feed rate	UN 	TiAlN	■	■	■	■	90-140	0.04-0.08	60-120	0.04-0.08	50-100	0.04-0.08	50-120	0.04-0.08
		Tmax	■	■	■	■	100-170	0.04-0.08	70-150	0.04-0.08	60-120	0.04-0.08	60-150	0.04-0.08
		Zmax	■	■	■	■	80-130*	0.04-0.10	50-110*	0.04-0.10	50-90*	0.04-0.10	50-120*	0.04-0.10
		ZTi6	■	■	■	■	110-200	0.04-0.08	80-160	0.04-0.08	70-140	0.04-0.08	70-160	0.04-0.08
	UR 	TiAlN	■	■	■	■	90-140	0.04-0.08	60-120	0.04-0.08	50-100	0.04-0.08	50-120	0.04-0.08
		Tmax	■	■	■	■	100-170	0.04-0.08	70-150	0.04-0.08	60-120	0.04-0.08	60-150	0.04-0.08
		Zmax	■	■	■	■	80-130*	0.04-0.10	50-110*	0.04-0.10	50-90*	0.04-0.10	50-120*	0.04-0.10
		ZTi6	■	■	■	■	110-200	0.04-0.08	80-160	0.04-0.08	70-140	0.04-0.08	70-160	0.04-0.08
	JN 	TiAlN	■	■	■	■	90-140	0.04-0.08	60-120	0.04-0.08	50-100	0.04-0.08	50-120	0.04-0.08
		Tmax	■	■	■	■	100-170	0.04-0.08	70-150	0.04-0.08	60-120	0.04-0.08	60-150	0.04-0.08
		Zmax	■	■	■	■	80-130*	0.04-0.10	50-110*	0.04-0.10	50-90*	0.04-0.10	50-120*	0.04-0.10
		ZTi6	■	■	■	■	110-200	0.04-0.08	80-160	0.04-0.08	70-140	0.04-0.08	70-160	0.04-0.08
	JR 	TiAlN	■	■	■	■	90-140	0.04-0.08	60-120	0.04-0.08	50-100	0.04-0.08	50-120	0.04-0.08
		Tmax	■	■	■	■	100-170	0.04-0.08	70-150	0.04-0.08	60-120	0.04-0.08	60-150	0.04-0.08
		Zmax	■	■	■	■	80-130*	0.04-0.10	50-110*	0.04-0.10	50-90*	0.04-0.10	50-120*	0.04-0.10
		ZTi6	■	■	■	■	110-200	0.04-0.08	80-160	0.04-0.08	70-140	0.04-0.08	70-160	0.04-0.08
	TN 	TiAlN	■	■	■	■	90-150	0.08-0.18	70-130	0.08-0.18	50-100	0.08-0.15	50-120	0.08-0.20
		Tmax	■	■	■	■	100-170	0.08-0.18	70-150	0.08-0.18	60-120	0.08-0.15	60-150	0.08-0.20
		Zmax	■	■	■	■	80-130*	0.08-0.18	50-110*	0.08-0.18	50-90*	0.08-0.15	50-120*	0.08-0.20
		ZTi6	■	■	■	■	110-200	0.08-0.18	80-160	0.08-0.18	70-140	0.08-0.15	70-160	0.08-0.20
	TR 	TiAlN	■	■	■	■	90-150	0.08-0.18	70-130	0.08-0.18	50-100	0.08-0.15	50-120	0.08-0.20
		Tmax	■	■	■	■	100-170	0.08-0.18	70-150	0.08-0.18	60-120	0.08-0.15	60-150	0.08-0.20
		Zmax	■	■	■	■	80-130*	0.08-0.18	50-110*	0.08-0.18	50-90*	0.08-0.15	50-120*	0.08-0.20
		ZTi6	■	■	■	■	110-200	0.08-0.18	80-160	0.08-0.18	70-140	0.08-0.15	70-160	0.08-0.20
Avance modérée Niedriger Vorschub Low feed rate	UN-000F 	TiAlN	■	■	■	■	80-120	0.02-0.05	50-100	0.02-0.05	40-80	0.02-0.05	40-100	0.02-0.05
		UR/ULF	TiAlN	■	■	■	■	80-120	0.02-0.05	50-100	0.02-0.05	40-80	0.02-0.05	40-100
	ANF 	N	■	■	■	■								
		TiAlN	■	■	■	■							40-80	0.02-0.05
	ARF 	N	■	■	■	■								
		TiAlN	■	■	■	■							40-80	0.02-0.05
		AS	■	■	■	■								

* premier choix en cas de coupe interrompue

** arête de coupe vive

* beste Basis für unterbrochene Schnitte

** scharfe Schneidkante

* first choice for interrupted cut

** sharp cutting edge

N Alliage d'aluminium et non ferreux Aluminium- und Nichteisenlegierungen Aluminium and non-ferrous alloys								S Titane Titan Titanium			
Aluminium		Alu silicium max. 5% Aluminiumsilicium max. 5% Aluminium silicon max. 5%		Cuivre Kupfer Copper		Laiton & bronze Messing & Bronze Brass & bronze		Gr. 1 - 3		Gr. 4 - 5	
VC (m/min)	F (mm/U)	VC (m/min)	F (mm/U)	VC (m/min)	F (mm/U)	VC (m/min)	F (mm/U)	VC (m/min)	F (mm/U)	VC (m/min)	F (mm/U)
100-250	0.03-0.10	100-250	0.03-0.10	100-300	0.03-0.10	100-300	0.03-0.10			50-100	0.04-0.08
100-250	0.03-0.10	100-250	0.03-0.10	100-300	0.03-0.10	100-300	0.03-0.10			50-100	0.04-0.08
100-250	0.03-0.10	100-250	0.03-0.10	100-300	0.03-0.10	100-300	0.03-0.10			50-100	0.04-0.08
100-250	0.03-0.10	100-250	0.03-0.10	100-300	0.03-0.10	100-300	0.03-0.10			50-100	0.04-0.08
						150-300	0.05-0.20				
						150-300	0.05-0.20				
100-300	0.02-0.06	100-200	0.01-0.05	100-250	0.01-0.05	100-300	0.02-0.06			50-100	0.01-0.06
100-300	0.02-0.06	100-200	0.01-0.05	100-250	0.01-0.05	100-300	0.02-0.06			50-100	0.01-0.06
80-200	0.02-0.06			80-200	0.01-0.05	80-200	0.02-0.06	50-100	0.01-0.06	50-100	0.01-0.06
100-250	0.02-0.06	80-150	0.01-0.05	100-200	0.01-0.05	80-200	0.02-0.06			30-80	0.01-0.06
100-300	0.02-0.06	100-200	0.01-0.05	100-250	0.01-0.05	100-300	0.02-0.06	50-120	0.01-0.06	50-120	0.01-0.06
80-200	0.02-0.06			80-200	0.01-0.05	80-200	0.02-0.06	50-100	0.01-0.06	50-100	0.01-0.06
100-250	0.02-0.06	80-150	0.01-0.05	100-200	0.01-0.05	80-200	0.02-0.06			30-80	0.01-0.06
100-300	0.02-0.06	100-200	0.01-0.05	100-250	0.01-0.05	100-300	0.02-0.06	50-120	0.01-0.06	50-120	0.01-0.06

