

PM-TECH

ZVYŠTE 
kvalitu povrchu.

SNIŽTE 
čas leštění.

Ocel
≤ 68 HRC

Ø 0,2 - Ø 12 mm

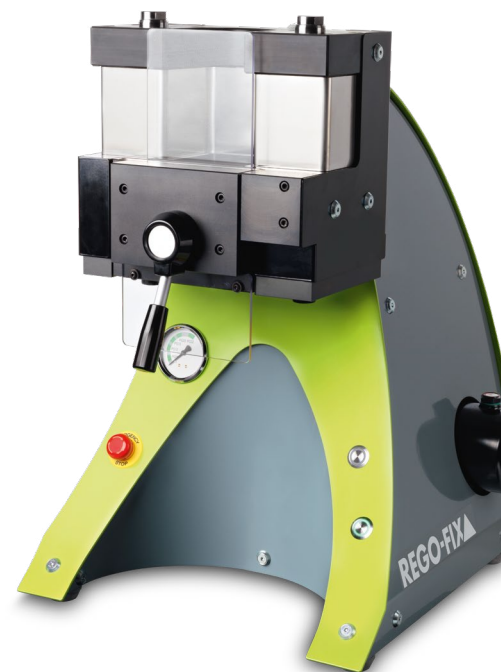

OBSAH

Typ		Provedení	Počet břitů	Rozsah průměrů (mm)	Úhel odlehčení θ	Stránka katalogu	
S KUŽELOVÝM ODLEHČENÍM		2JJTB	KULOVÉ	2	Ø0,2 - Ø12	0°30' 1° 1°30' 2° 3° 5°	str. 3 - 6
		3JJTBS	KULOVÉ	3	Ø1,0 - Ø12	podle požadavku	str. 7
		2JJTC	TOROIDNÍ	2	Ø1,0 - Ø4,0	1°	str. 8 - 9
		4JJTC	TOROIDNÍ	4	Ø1,0 - Ø4,0	1°	str. 10
		2PHCB	KULOVÉ ultrapřesné	2	Ø0,2 - Ø12	bez odlehčení	str. 11
BEZ ODLEHČENÍ							

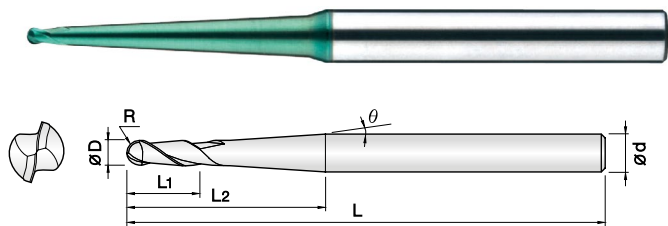

- ▶ Určeno pro kalené oceli (52 - 68 HRC)
- ▶ Vysoká odolnost proti opotřebení díky PVD povlaku na bázi Si
- ▶ Velmi přesné tolerance rezných hran
- ▶ Široký sortiment vyložení a úhlů pro optimální výběr nástroje
- ▶ Vysoká tuhost díky kuželovému odlehčení
- ▶ Vynikající výkon při vysokých rezných rychlostech díky 0,2 μm tvrdkovu

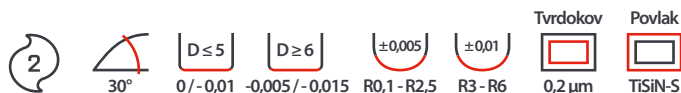

NOVINKA

Objednací číslo	D (mm)	R (mm)	Úhel θ	L2 (mm)	L1 (mm)	L (mm)	d h5 (mm)	Standardní položka		
2JJTB-002-003-015	0,2	R 0,1	0°30'	1,5	0,2	40	4	☑		
2JJTB-002-003-020			0°30'	2	0,2	40	4	☑		
2JJTB-002-010-015			1°	1,5	0,2	40	4	☑		
2JJTB-002-010-020			1°	2	0,2	40	4	☑		
2JJTB-002-010-025			1°	2,5	0,2	40	4	☑		
2JJTB-002-013-015			1°30'	1,5	0,2	40	4	☑		
2JJTB-002-013-020			1°30'	2	0,2	40	4	☑		
2JJTB-002-013-025			1°30'	2,5	0,2	40	4	☑		
2JJTB-002-020-015			2°	1,5	0,2	40	4	☑		
2JJTB-002-020-020			2°	2	0,2	40	4	☑		
2JJTB-002-020-025			2°	2,5	0,2	40	4	☑		
2JJTB-002-030-015			3°	1,5	0,2	40	4	☑		
2JJTB-002-030-020			3°	2	0,2	40	4	☑		
2JJTB-002-030-025			3°	2,5	0,2	40	4	☑		
2JJTB-002-030-030			3°	3	0,2	45	4	☑		
2JJTB-002-050-020			5°	2	0,2	40	4	☑		
2JJTB-002-050-030			5°	3	0,2	45	4	☑		
2JJTB-003-003-030			0,3	R 0,15	0°30'	3	0,3	40	4	☑
2JJTB-003-010-020					1°	2	0,3	40	4	☑
2JJTB-003-010-030					1°	3	0,3	40	4	☑
2JJTB-003-010-040	1°	4			0,3	40	4	☑		
2JJTB-003-010-050	1°	5			0,3	40	4	☑		
2JJTB-003-013-020	1°30'	2			0,3	40	4	☑		
2JJTB-003-013-030	1°30'	3			0,3	40	4	☑		
2JJTB-003-013-040	1°30'	4			0,3	40	4	☑		
2JJTB-003-013-050	1°30'	5			0,3	40	4	☑		
2JJTB-003-020-020	2°	2			0,3	40	4	☑		
2JJTB-003-020-030	2°	3			0,3	40	4	☑		
2JJTB-003-020-040	2°	4			0,3	40	4	☑		
2JJTB-003-020-050	2°	5			0,3	40	4	☑		
2JJTB-003-020-060	2°	6			0,3	45	4	☑		
2JJTB-003-030-020	3°	2			0,3	40	4	☑		
2JJTB-003-030-030	3°	3			0,3	40	4	☑		
2JJTB-003-030-040	3°	4			0,3	40	4	☑		
2JJTB-003-030-050	3°	5			0,3	40	4	☑		
2JJTB-003-030-060	3°	6			0,3	45	4	☑		
2JJTB-003-050-050	5°	5			0,3	40	4	☑		
2JJTB-003-050-080	5°	8			0,3	45	4	☑		

Objednací číslo	D (mm)	R (mm)	Úhel θ	L2 (mm)	L1 (mm)	L (mm)	d h5 (mm)	Standardní položka
2JJTB-004-003-020	0,4	R 0,2	0°30'	2	0,4	40	4	☑
2JJTB-004-003-030			0°30'	3	0,4	40	4	☑
2JJTB-004-003-040			0°30'	4	0,4	40	4	☑
2JJTB-004-003-050			0°30'	5	0,4	40	4	☑
2JJTB-004-003-060			0°30'	6	0,4	40	4	☑
2JJTB-004-010-020			1°	2	0,4	40	4	☑
2JJTB-004-010-030			1°	3	0,4	40	4	☑
2JJTB-004-010-040			1°	4	0,4	40	4	☑
2JJTB-004-010-050			1°	5	0,4	40	4	☑
2JJTB-004-010-060			1°	6	0,4	40	4	☑
2JJTB-004-010-080			1°	8	0,4	45	4	☑
2JJTB-004-013-020			1°30'	2	0,4	40	4	☑
2JJTB-004-013-030			1°30'	3	0,4	40	4	☑
2JJTB-004-013-040			1°30'	4	0,4	40	4	☑
2JJTB-004-013-050			1°30'	5	0,4	40	4	☑
2JJTB-004-013-060			1°30'	6	0,4	40	4	☑
2JJTB-004-013-080			1°30'	8	0,4	45	4	☑
2JJTB-004-020-020			2°	2	0,4	40	4	☑
2JJTB-004-020-030			2°	3	0,4	40	4	☑
2JJTB-004-020-040			2°	4	0,4	40	4	☑
2JJTB-004-020-050			2°	5	0,4	40	4	☑
2JJTB-004-020-060			2°	6	0,4	40	4	☑
2JJTB-004-020-080			2°	8	0,4	45	4	☑
2JJTB-004-020-100			2°	10	0,4	45	4	☑
2JJTB-004-030-040			3°	4	0,4	45	4	☑
2JJTB-004-030-060			3°	6	0,4	45	4	☑
2JJTB-004-030-080			3°	8	0,4	45	4	☑
2JJTB-004-030-100			3°	10	0,4	45	4	☑
2JJTB-004-050-060			5°	6	0,4	45	4	☑
2JJTB-004-050-080			5°	8	0,4	45	4	☑
2JJTB-004-050-100			5°	10	0,4	45	4	☑
2JJTB-005-003-040			0,5	R 0,25	0°30'	4	0,5	45
2JJTB-005-003-060	0°30'	6			0,5	45	4	☑
2JJTB-005-010-040	1°	4			0,5	45	4	☑
2JJTB-005-010-060	1°	6			0,5	45	4	☑
2JJTB-005-010-080	1°	8			0,5	45	4	☑
2JJTB-005-010-100	1°	10			0,5	45	4	☑
2JJTB-005-013-040	1°30'	4			0,5	45	4	☑

Objednací číslo	D (mm)	R (mm)	Úhel θ	L2 (mm)	L1 (mm)	L (mm)	d h5 (mm)	Standardní položka
2JJTB-005-013-060	0,5	R 0,25	1°30'	6	0.5	45	4	☑
2JJTB-005-013-080			1°30'	8	0.5	45	4	☑
2JJTB-005-013-100			1°30'	10	0.5	45	4	☑
2JJTB-005-020-040			2°	4	0.5	45	4	☑
2JJTB-005-020-060			2°	6	0.5	45	4	☑
2JJTB-005-020-080			2°	8	0.5	45	4	☑
2JJTB-005-020-100			2°	10	0.5	45	4	☑
2JJTB-005-030-080			3°	8	0.5	45	4	☑
2JJTB-005-030-120			3°	12	0.5	50	4	☑
2JJTB-005-030-160			3°	16	0.5	60	4	☑
2JJTB-005-030-200			3°	20	0.5	60	4	☑
2JJTB-005-050-100			5°	10	0.5	50	4	☑
2JJTB-005-050-150			5°	15	0.5	60	4	☑
2JJTB-005-050-200			5°	20	0.5	60	4	☑
2JJTB-006-003-040	0,6	R 0,3	0°30'	4	0.6	45	4	☑
2JJTB-006-003-060			0°30'	6	0.6	45	4	☑
2JJTB-006-003-080			0°30'	8	0.6	45	4	☑
2JJTB-006-010-040			1°	4	0.6	45	4	☑
2JJTB-006-010-060			1°	6	0.6	45	4	☑
2JJTB-006-010-080			1°	8	0.6	45	4	☑
2JJTB-006-010-100			1°	10	0.6	45	4	☑
2JJTB-006-010-120			1°	12	0.6	50	4	☑
2JJTB-006-010-150			1°	15	0.6	50	4	☑
2JJTB-006-010-200			1°	20	0.6	60	4	☑
2JJTB-006-013-040			1°30'	4	0.6	45	4	☑
2JJTB-006-013-060			1°30'	6	0.6	45	4	☑
2JJTB-006-013-080			1°30'	8	0.6	45	4	☑
2JJTB-006-013-100			1°30'	10	0.6	45	4	☑
2JJTB-006-013-120			1°30'	12	0.6	50	4	☑
2JJTB-006-013-150			1°30'	15	0.6	50	4	☑
2JJTB-006-013-200			1°30'	20	0.6	60	4	☑
2JJTB-006-020-060			2°	6	0.6	45	4	☑
2JJTB-006-020-080			2°	8	0.6	45	4	☑
2JJTB-006-020-100			2°	10	0.6	45	4	☑
2JJTB-006-020-150			2°	15	0.6	50	4	☑
2JJTB-006-020-200			2°	20	0.6	60	4	☑
2JJTB-006-030-130			3°	13	0.6	50	4	☑
2JJTB-006-030-160			3°	16	0.6	60	4	☑
2JJTB-006-030-200			3°	20	0.6	60	4	☑
2JJTB-006-050-100			5°	10	0.6	50	4	☑
2JJTB-006-050-150			5°	15	0.6	60	4	☑
2JJTB-006-050-200			5°	20	0.6	60	4	☑
2JJTB-008-003-040	0,8	R 0,4	0°30'	4	0.8	45	4	☑
2JJTB-008-003-060			0°30'	6	0.8	45	4	☑
2JJTB-008-003-080			0°30'	8	0.8	45	4	☑
2JJTB-008-003-100			0°30'	10	0.8	45	4	☑
2JJTB-008-003-120			0°30'	12	0.8	50	4	☑
2JJTB-008-003-150			0°30'	15	0.8	50	4	☑
2JJTB-008-003-200			0°30'	20	0.8	60	4	☑
2JJTB-008-003-250			0°30'	25	0.8	70	4	☑
2JJTB-008-010-040			1°	4	0.8	45	4	☑
2JJTB-008-010-060			1°	6	0.8	45	4	☑

Objednací číslo	D (mm)	R (mm)	Úhel θ	L2 (mm)	L1 (mm)	L (mm)	d h5 (mm)	Standardní položka
2JJTB-008-010-080	0,8	R 0,4	1°	8	0.8	45	4	☑
2JJTB-008-010-100			1°	10	0.8	45	4	☑
2JJTB-008-010-120			1°	12	0.8	50	4	☑
2JJTB-008-010-160			1°	16	0.8	50	4	☑
2JJTB-008-010-200			1°	20	0.8	60	4	☑
2JJTB-008-010-250			1°	25	0.8	70	4	☑
2JJTB-008-013-040			1°30'	4	0.8	45	4	☑
2JJTB-008-013-060			1°30'	6	0.8	45	4	☑
2JJTB-008-013-080			1°30'	8	0.8	45	4	☑
2JJTB-008-013-100			1°30'	10	0.8	45	4	☑
2JJTB-008-013-120			1°30'	12	0.8	50	4	☑
2JJTB-008-013-160			1°30'	16	0.8	50	4	☑
2JJTB-008-013-200			1°30'	20	0.8	60	4	☑
2JJTB-008-013-250			1°30'	25	0.8	70	4	☑
2JJTB-008-020-080			2°	8	0.8	50	4	☑
2JJTB-008-020-100			2°	10	0.8	50	4	☑
2JJTB-008-020-120			2°	12	0.8	50	4	☑
2JJTB-008-020-160			2°	16	0.8	50	4	☑
2JJTB-008-020-200			2°	20	0.8	60	4	☑
2JJTB-008-020-250			2°	25	0.8	70	4	☑
2JJTB-008-030-080			3°	8	0.8	50	4	☑
2JJTB-008-030-120			3°	12	0.8	50	4	☑
2JJTB-008-030-160			3°	16	0.8	50	4	☑
2JJTB-008-030-200			3°	20	0.8	60	4	☑
2JJTB-008-030-250	3°	25	0.8	70	4	☑		
2JJTB-008-050-240	5°	24	0.8	60	6	☑		
2JJTB-010-003-060	1	R 0,5	0°30'	6	1	50	4	☑
2JJTB-010-003-080			0°30'	8	1	50	4	☑
2JJTB-010-003-100			0°30'	10	1	50	4	☑
2JJTB-010-003-150			0°30'	15	1	50	4	☑
2JJTB-010-003-200			0°30'	20	1	60	4	☑
2JJTB-010-003-250			0°30'	25	1	60	4	☑
2JJTB-010-003-300			0°30'	30	1	70	4	☑
2JJTB-010-010-060			1°	6	1	50	4	☑
2JJTB-010-010-080			1°	8	1	50	4	☑
2JJTB-010-010-100			1°	10	1	50	4	☑
2JJTB-010-010-150			1°	15	1	50	4	☑
2JJTB-010-010-200			1°	20	1	50	4	☑
2JJTB-010-010-250			1°	25	1	60	4	☑
2JJTB-010-010-300			1°	30	1	70	4	☑
2JJTB-010-010-350			1°	35	1	75	4	☑
2JJTB-010-013-060			1°30'	6	1	50	4	☑
2JJTB-010-013-080			1°30'	8	1	50	4	☑
2JJTB-010-013-100			1°30'	10	1	50	4	☑
2JJTB-010-013-150			1°30'	15	1	50	4	☑
2JJTB-010-013-200			1°30'	20	1	50	4	☑
2JJTB-010-013-250			1°30'	25	1	60	4	☑
2JJTB-010-013-300			1°30'	30	1	70	4	☑
2JJTB-010-013-350			1°30'	35	1	80	4	☑
2JJTB-010-013-400			1°30'	40	1	80	4	☑
2JJTB-010-020-150	2°	15	1	50	4	☑		
2JJTB-010-020-200	2°	20	1	50	4	☑		

Objednací číslo	D (mm)	R (mm)	Úhel θ	L2 (mm)	L1 (mm)	L (mm)	d h5 (mm)	Standardní položka		
2JJTB-010-020-250	1	R 0,5	2°	25	1	60	4	☑		
2JJTB-010-020-300			2°	30	1	70	4	☑		
2JJTB-010-020-400			2°	40	1	80	4	☑		
2JJTB-010-030-200			3°	20	1	50	4	☑		
2JJTB-010-030-300			3°	30	1	70	6	☑		
2JJTB-010-030-400			3°	40	1	80	6	☑		
2JJTB-010-030-500			3°	50	1	90	6	☑		
2JJTB-010-050-230			5°	23	1	60	6	☑		
2JJTB-012-003-080			1,2	R 0,6	0°30'	8	1,2	50	4	☑
2JJTB-012-003-120	0°30'	12			1,2	50	4	☑		
2JJTB-012-003-180	0°30'	18			1,2	50	4	☑		
2JJTB-012-003-240	0°30'	24			1,2	60	4	☑		
2JJTB-012-010-080	1°	8			1,2	50	4	☑		
2JJTB-012-010-120	1°	12			1,2	50	4	☑		
2JJTB-012-010-180	1°	18			1,2	50	4	☑		
2JJTB-012-010-240	1°	24			1,2	60	4	☑		
2JJTB-012-013-080	1°30'	8			1,2	50	4	☑		
2JJTB-012-013-120	1°30'	12			1,2	50	4	☑		
2JJTB-012-013-180	1°30'	18			1,2	50	4	☑		
2JJTB-012-013-240	1°30'	24			1,2	60	4	☑		
2JJTB-012-020-080	2°	8			1,2	50	4	☑		
2JJTB-012-020-120	2°	12			1,2	50	4	☑		
2JJTB-012-020-180	2°	18			1,2	50	4	☑		
2JJTB-012-020-240	2°	24			1,2	60	4	☑		
2JJTB-015-003-080	1,5	R 0,75			0°30'	8	1,5	50	4	☑
2JJTB-015-003-100					0°30'	10	1,5	50	4	☑
2JJTB-015-003-120			0°30'	12	1,5	50	4	☑		
2JJTB-015-003-150			0°30'	15	1,5	50	4	☑		
2JJTB-015-003-200			0°30'	20	1,5	60	4	☑		
2JJTB-015-003-300			0°30'	30	1,5	70	4	☑		
2JJTB-015-003-400			0°30'	40	1,5	80	4	☑		
2JJTB-015-010-080			1°	8	1,5	50	4	☑		
2JJTB-015-010-100			1°	10	1,5	50	4	☑		
2JJTB-015-010-120			1°	12	1,5	50	4	☑		
2JJTB-015-010-150			1°	15	1,5	50	4	☑		
2JJTB-015-010-200			1°	20	1,5	60	4	☑		
2JJTB-015-010-250			1°	25	1,5	60	4	☑		
2JJTB-015-010-300			1°	30	1,5	70	4	☑		
2JJTB-015-010-400			1°	40	1,5	80	4	☑		
2JJTB-015-010-500			1°	50	1,5	90	4	☑		
2JJTB-015-013-080			1°30'	8	1,5	50	4	☑		
2JJTB-015-013-100			1°30'	10	1,5	50	4	☑		
2JJTB-015-013-120			1°30'	12	1,5	50	4	☑		
2JJTB-015-013-150			1°30'	15	1,5	50	4	☑		
2JJTB-015-013-200			1°30'	20	1,5	60	4	☑		
2JJTB-015-013-250			1°30'	25	1,5	60	4	☑		
2JJTB-015-013-300			1°30'	30	1,5	70	4	☑		
2JJTB-015-013-400			1°30'	40	1,5	80	4	☑		
2JJTB-015-013-500			1°30'	50	1,5	90	4	☑		
2JJTB-015-020-100			2°	10	1,5	50	4	☑		
2JJTB-015-020-150			2°	15	1,5	50	4	☑		
2JJTB-015-020-200			2°	20	1,5	60	4	☑		

Objednací číslo	D (mm)	R (mm)	Úhel θ	L2 (mm)	L1 (mm)	L (mm)	d h5 (mm)	Standardní položka
2JJTB-015-020-300	1,5	R 0,75	2°	30	1,5	70	4	☑
2JJTB-015-020-400			2°	40	1,5	80	6	☑
2JJTB-015-020-500			2°	50	1,5	90	6	☑
2JJTB-015-030-420			3°	42	1,5	80	6	☑
2JJTB-015-050-250			5°	25	1,5	70	6	☑
2JJTB-020-003-080			2	R 1	0°30'	8	2	50
2JJTB-020-003-120	0°30'	12			2	50	4	☑
2JJTB-020-003-160	0°30'	16			2	50	4	☑
2JJTB-020-003-200	0°30'	20			2	60	4	☑
2JJTB-020-003-300	0°30'	30			2	70	4	☑
2JJTB-020-003-400	0°30'	40			2	80	4	☑
2JJTB-020-003-500	0°30'	50			2	90	4	☑
2JJTB-020-010-080	1°	8			2	50	4	☑
2JJTB-020-010-120	1°	12			2	50	4	☑
2JJTB-020-010-160	1°	16			2	50	4	☑
2JJTB-020-010-200	1°	20			2	60	4	☑
2JJTB-020-010-250	1°	25			2	60	4	☑
2JJTB-020-010-300	1°	30			2	70	4	☑
2JJTB-020-010-350	1°	35			2	75	4	☑
2JJTB-020-010-400	1°	40			2	80	4	☑
2JJTB-020-010-500	1°	50			2	90	4	☑
2JJTB-020-010-600	1°	60			2	100	6	☑
2JJTB-020-013-080	1°30'	8			2	50	4	☑
2JJTB-020-013-120	1°30'	12			2	50	4	☑
2JJTB-020-013-160	1°30'	16			2	50	4	☑
2JJTB-020-013-200	1°30'	20			2	60	4	☑
2JJTB-020-013-250	1°30'	25			2	60	4	☑
2JJTB-020-013-300	1°30'	30			2	70	4	☑
2JJTB-020-013-350	1°30'	35			2	75	6	☑
2JJTB-020-013-400	1°30'	40	2	80	6	☑		
2JJTB-020-013-500	1°30'	50	2	90	6	☑		
2JJTB-020-013-600	1°30'	60	2	100	6	☑		
2JJTB-020-020-300	2°	30	2	70	6	☑		
2JJTB-020-020-400	2°	40	2	80	6	☑		
2JJTB-020-020-500	2°	50	2	90	6	☑		
2JJTB-020-030-300	3°	30	2	70	6	☑		
2JJTB-020-030-400	3°	40	2	80	6	☑		
2JJTB-020-030-500	3°	50	2	90	8	☑		
2JJTB-020-050-250	5°	25	2	60	6	☑		
2JJTB-020-050-380	5°	38	2	80	8	☑		
2JJTB-030-003-160	3	R 1,5	0°30'	16	3	60	6	☑
2JJTB-030-003-200			0°30'	20	3	65	6	☑
2JJTB-030-003-300			0°30'	30	3	70	6	☑
2JJTB-030-003-400			0°30'	40	3	80	6	☑
2JJTB-030-003-500			0°30'	50	3	90	6	☑
2JJTB-030-003-600			0°30'	60	3	100	6	☑
2JJTB-030-010-160			1°	16	3	60	6	☑
2JJTB-030-010-200			1°	20	3	65	6	☑
2JJTB-030-010-300			1°	30	3	70	6	☑
2JJTB-030-010-400			1°	40	3	80	6	☑
2JJTB-030-010-500			1°	50	3	90	6	☑
2JJTB-030-010-600			1°	60	3	100	6	☑

Objednací číslo	D (mm)	R (mm)	Úhel θ	L2 (mm)	L1 (mm)	L (mm)	d h5 (mm)	Standardní položka		
2JJTB-030-010-700	3	R 1,5	1°	70	3	110	6	<input checked="" type="checkbox"/>		
2JJTB-030-013-160			1°30'	16	3	60	6	<input checked="" type="checkbox"/>		
2JJTB-030-013-200			1°30'	20	3	65	6	<input checked="" type="checkbox"/>		
2JJTB-030-013-300			1°30'	30	3	70	6	<input checked="" type="checkbox"/>		
2JJTB-030-013-400			1°30'	40	3	80	6	<input checked="" type="checkbox"/>		
2JJTB-030-013-500			1°30'	50	3	90	6	<input checked="" type="checkbox"/>		
2JJTB-030-013-600			1°30'	60	3	100	6	<input checked="" type="checkbox"/>		
2JJTB-030-013-700			1°30'	70	3	120	8	<input checked="" type="checkbox"/>		
2JJTB-030-020-160			2°	16	3	60	6	<input checked="" type="checkbox"/>		
2JJTB-030-020-200			2°	20	3	65	6	<input checked="" type="checkbox"/>		
2JJTB-030-020-300			2°	30	3	70	6	<input checked="" type="checkbox"/>		
2JJTB-030-020-480			2°	48	3	90	6	<input checked="" type="checkbox"/>		
2JJTB-030-020-600			2°	60	3	110	8	<input checked="" type="checkbox"/>		
2JJTB-030-020-700			2°	70	3	120	8	<input checked="" type="checkbox"/>		
2JJTB-030-030-300			3°	30	3	70	6	<input checked="" type="checkbox"/>		
2JJTB-030-030-500			3°	50	3	90	8	<input checked="" type="checkbox"/>		
2JJTB-030-030-700			3°	70	3	120	10	<input checked="" type="checkbox"/>		
2JJTB-030-050-330			5°	33	3	90	8	<input checked="" type="checkbox"/>		
2JJTB-040-003-600			4	R 2	0°30'	60	4	100	6	<input checked="" type="checkbox"/>
2JJTB-040-003-700					0°30'	70	4	110	6	<input checked="" type="checkbox"/>
2JJTB-040-003-900	0°30'	90			4	130	6	<input checked="" type="checkbox"/>		
2JJTB-040-010-500	1°	50			4	90	6	<input checked="" type="checkbox"/>		
2JJTB-040-010-600	1°	60			4	100	6	<input checked="" type="checkbox"/>		
2JJTB-040-010-700	1°	70			4	120	8	<input checked="" type="checkbox"/>		
2JJTB-040-010-900	1°	90			4	150	8	<input checked="" type="checkbox"/>		
2JJTB-040-013-450	1°30'	45			4	90	6	<input checked="" type="checkbox"/>		
2JJTB-040-013-600	1°30'	60			4	110	8	<input checked="" type="checkbox"/>		
2JJTB-040-013-700	1°30'	70			4	120	8	<input checked="" type="checkbox"/>		
2JJTB-040-030-250	3°	25			4	70	6	<input checked="" type="checkbox"/>		
2JJTB-040-030-420	3°	42			4	100	8	<input checked="" type="checkbox"/>		
2JJTB-040-050-290	5°	29			4	90	8	<input checked="" type="checkbox"/>		
2JJTB-050-010-400	5	R 2,5			1°	40	5	90	8	<input checked="" type="checkbox"/>
2JJTB-050-010-600			1°	60	5	110	8	<input checked="" type="checkbox"/>		
2JJTB-050-010-900			1°	90	5	150	8	<input checked="" type="checkbox"/>		
2JJTB-050-013-400			1°30'	40	5	90	8	<input checked="" type="checkbox"/>		
2JJTB-050-013-600			1°30'	60	5	110	8	<input checked="" type="checkbox"/>		
2JJTB-050-013-900			1°30'	90	5	150	10	<input checked="" type="checkbox"/>		
2JJTB-050-030-400			3°	40	5	90	8	<input checked="" type="checkbox"/>		
2JJTB-060-010-400			6	R 3	1°	40	9	90	8	<input checked="" type="checkbox"/>
2JJTB-060-010-500	1°	50			9	100	8	<input checked="" type="checkbox"/>		
2JJTB-060-010-600	1°	60			9	110	8	<input checked="" type="checkbox"/>		
2JJTB-060-010-700	1°	70			9	120	10	<input checked="" type="checkbox"/>		
2JJTB-060-010-800	1°	80			9	130	10	<input checked="" type="checkbox"/>		
2JJTB-060-010-1000	1°	100			9	150	10	<input checked="" type="checkbox"/>		
2JJTB-060-013-490	1°30'	49			9	110	8	<input checked="" type="checkbox"/>		
2JJTB-060-013-850	1°30'	85			9	150	10	<input checked="" type="checkbox"/>		
2JJTB-060-020-600	2°	60			9	110	10	<input checked="" type="checkbox"/>		
2JJTB-060-020-900	2°	90			9	150	12	<input checked="" type="checkbox"/>		
2JJTB-060-030-290	3°	29			9	90	8	<input checked="" type="checkbox"/>		
2JJTB-060-050-320	5°	32			9	110	10	<input checked="" type="checkbox"/>		
2JJTB-080-010-500	8	R 4			1°	50	12	100	10	<input checked="" type="checkbox"/>
2JJTB-080-010-600					1°	60	12	110	10	<input checked="" type="checkbox"/>

▶ 3JJTBS

3-břité KULOVÉ frézy s kuželovým odlehčením pro žebrování pro kalené oceli do HRC 68

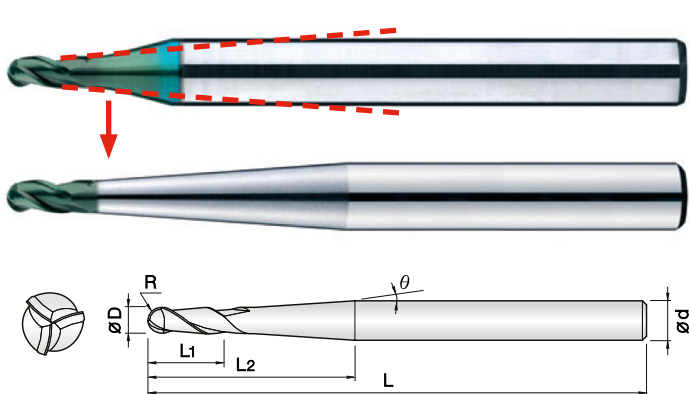

- ▶ Určeno pro kalené oceli (52 - 68 HRC)
- ▶ Vysoká odolnost proti opotřebení díky novému PVD povlaku s vysokým obsahem Si
- ▶ Velmi přesné tolerance řezných hran
- ▶ Rychlá úprava úhlu a délky odlehčení podle Vašich požadavků
- ▶ Vynikající výkon při vysokých řezných rychlostech díky 0,2 μm tvrdokovu



Tvrdokov

Povlak

0,2 μm

TiSiN-S

Objednáací číslo	D (mm)	R (mm)	Úhel θ	L2 (mm)	L1 (mm)	L (mm)	d h5 (mm)	Standardní položka
3JJTBS-010-060-S04	1	R 0,5	Do objednávky prosím zadejte VÁMI POŽADOVANÝ ÚHEL.	Do objednávky prosím zadejte VÁMI POŽADOVANOU DÉLKU ODLEHČENÍ.	1	60	4	<input checked="" type="checkbox"/>
3JJTBS-010-080-S04					1	80	4	<input checked="" type="checkbox"/>
3JJTBS-010-090-S06					1	90	6	<input checked="" type="checkbox"/>
3JJTBS-015-060-S04	1,5	R 0,75			1,5	60	4	<input checked="" type="checkbox"/>
3JJTBS-015-080-S04					1,5	80	4	<input checked="" type="checkbox"/>
3JJTBS-015-090-S06					1,5	90	6	<input checked="" type="checkbox"/>
3JJTBS-020-070-S04	2	R 1			2	70	4	<input checked="" type="checkbox"/>
3JJTBS-020-090-S04					2	90	4	<input checked="" type="checkbox"/>
3JJTBS-020-090-S06					2	90	6	<input checked="" type="checkbox"/>
3JJTBS-030-080-S06	3	R 1,5			3	80	6	<input checked="" type="checkbox"/>
3JJTBS-030-100-S06					3	100	6	<input checked="" type="checkbox"/>
3JJTBS-030-110-S08					3	110	8	<input checked="" type="checkbox"/>
3JJTBS-040-080-S06	4	R 2			5	80	6	<input checked="" type="checkbox"/>
3JJTBS-040-110-S06					5	110	6	<input checked="" type="checkbox"/>
3JJTBS-040-120-S08					5	120	8	<input checked="" type="checkbox"/>
3JJTBS-050-090-S08	5	R 2,5			7	90	8	<input checked="" type="checkbox"/>
3JJTBS-050-120-S08					7	120	8	<input checked="" type="checkbox"/>
3JJTBS-060-110-S08					9	110	8	<input checked="" type="checkbox"/>
3JJTBS-060-150-S10	6	R 3	9	150	10	<input checked="" type="checkbox"/>		
3JJTBS-080-120-S10			12	120	10	<input checked="" type="checkbox"/>		
3JJTBS-080-160-S12	8	R 4	12	160	12	<input checked="" type="checkbox"/>		
3JJTBS-100-120-S12			10	R 5	15	120	12	<input checked="" type="checkbox"/>
3JJTBS-100-160-S12					15	160	12	<input checked="" type="checkbox"/>
3JJTBS-120-160-S16	12	R 6	18	160	16	<input checked="" type="checkbox"/>		
3JJTBS-120-200-S16			18	200	16	<input checked="" type="checkbox"/>		



Příklad objednávky:

Fréza 3JJTBS-010-060-S04
s úhlem odlehčení 1° a délkou odlehčení 20mm

3JJTBS-010-060-S04 θ=1° L2=20mm

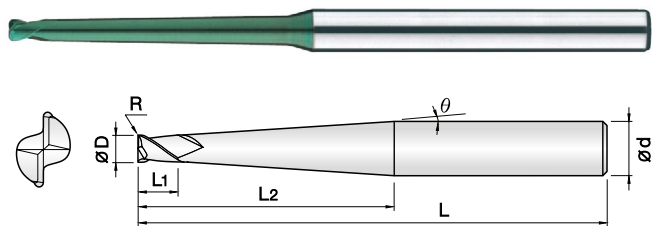

- Určeno pro kalené oceli (52 - 68 HRC)
- Vysoká odolnost proti opotřeбенí díky PVD povlaku na bázi Si
- Velmi přesné tolerance řezných hran
- Široký sortiment rádiusů a vyložení pro optimální výběr nástroje
- Vysoká tuhost díky kuželovému odlehčení
- Vynikající výkon při vysokých řezných rychlostech díky 0,2 µm tvrdokovu

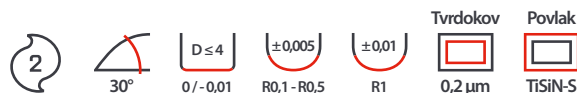

Objednací číslo	D (mm)	R (mm)	Úhel θ	L2 (mm)	L1 (mm)	L (mm)	d h5 (mm)	Standardní položka		
2JJTC-010-001-0601	1	R0,1	1°	6	1	50	4	☑		
2JJTC-010-001-1001			1°	10	1	50	4	☑		
2JJTC-010-001-1501			1°	15	1	50	4	☑		
2JJTC-010-001-2001			1°	20	1	60	4	☑		
2JJTC-010-001-2501			1°	25	1	60	4	☑		
2JJTC-010-001-3001			1°	30	1	70	4	☑		
2JJTC-010-001-3501			1°	35	1	75	4	☑		
2JJTC-010-002-0601			R0,2	1°	6	1	50	4	☑	
2JJTC-010-002-1001				1°	10	1	50	4	☑	
2JJTC-010-002-1501				1°	15	1	50	4	☑	
2JJTC-010-002-2001		1°		20	1	60	4	☑		
2JJTC-010-002-2501		1°		25	1	60	4	☑		
2JJTC-010-002-3001		1°		30	1	70	4	☑		
2JJTC-010-002-3501		1°		35	1	75	4	☑		
2JJTC-010-003-0601		R0,3		1°	6	1	50	4	☑	
2JJTC-010-003-1001				1°	10	1	50	4	☑	
2JJTC-010-003-1501				1°	15	1	50	4	☑	
2JJTC-010-003-2001			1°	20	1	60	4	☑		
2JJTC-010-003-2501			1°	25	1	60	4	☑		
2JJTC-010-003-3001			1°	30	1	70	4	☑		
2JJTC-010-003-3501			1°	35	1	75	4	☑		
2JJTC-015-002-1001			1,5	R0,2	1°	10	1,5	50	4	☑
2JJTC-015-002-1501					1°	15	1,5	50	4	☑
2JJTC-015-002-2001					1°	20	1,5	60	4	☑
2JJTC-015-002-2501		1°			25	1,5	60	4	☑	
2JJTC-015-002-3001		1°			30	1,5	70	4	☑	
2JJTC-015-002-3501		1°			35	1,5	75	4	☑	
2JJTC-015-003-1001		R0,3			1°	10	1,5	50	4	☑
2JJTC-015-003-1501					1°	15	1,5	50	4	☑
2JJTC-015-003-2001					1°	20	1,5	60	4	☑
2JJTC-015-003-2501	1°				25	1,5	60	4	☑	
2JJTC-015-003-3001	1°			30	1,5	70	4	☑		
2JJTC-015-003-3501	1°			35	1,5	75	4	☑		
2JJTC-015-005-1001	R0,5			1°	10	1,5	50	4	☑	
2JJTC-015-005-1501				1°	15	1,5	50	4	☑	
2JJTC-015-005-2001				1°	20	1,5	60	4	☑	
2JJTC-015-005-2501				1°	25	1,5	60	4	☑	
2JJTC-015-005-3001		1°		30	1,5	70	4	☑		
2JJTC-015-005-3501		1°		35	1,5	75	4	☑		

Objednací číslo	D (mm)	R (mm)	Úhel θ	L2 (mm)	L1 (mm)	L (mm)	d h5 (mm)	Standardní položka		
2JJTC-015-005-3501	1,5	R0,5	1°	35	1,5	75	4	☑		
2JJTC-020-002-1201			2	R0,2	1°	12	2	50	4	☑
2JJTC-020-002-1601					1°	16	2	50	4	☑
2JJTC-020-002-2001					1°	20	2	60	4	☑
2JJTC-020-002-2501					1°	25	2	60	4	☑
2JJTC-020-002-3001		1°			30	2	70	4	☑	
2JJTC-020-002-3501		1°		35	2	75	4	☑		
2JJTC-020-002-4001		R0,3		1°	40	2	80	4	☑	
2JJTC-020-002-5001				1°	50	2	90	4	☑	
2JJTC-020-003-1201				3	R0,3	1°	12	2	50	4
2JJTC-020-003-1601	1°					16	2	50	4	☑
2JJTC-020-003-2001	1°		20			2	60	4	☑	
2JJTC-020-003-2501	1°	25	2			60	4	☑		
2JJTC-020-003-3001	1°	30	2			70	4	☑		
2JJTC-020-003-3501	1°	35	2		75	4	☑			
2JJTC-020-003-4001	R0,5	1°	40		2	80	4	☑		
2JJTC-020-003-5001		1°	50		2	90	4	☑		
2JJTC-020-005-1201		3	R0,2		1°	12	2	50	4	☑
2JJTC-020-005-1601					1°	16	2	50	4	☑
2JJTC-020-005-2001				1°	20	2	60	4	☑	
2JJTC-020-005-2501	1°			25	2	60	4	☑		
2JJTC-020-005-3001	1°			30	2	70	4	☑		
2JJTC-020-005-3501	1°		35	2	75	4	☑			
2JJTC-020-005-4001	R0,3		1°	40	2	80	4	☑		
2JJTC-020-005-5001			1°	50	2	90	4	☑		
2JJTC-030-002-2001			3	R0,2	1°	20	3	60	6	☑
2JJTC-030-002-3001					1°	30	3	70	6	☑
2JJTC-030-002-4001		1°			40	3	80	6	☑	
2JJTC-030-002-5001	1°	50			3	90	6	☑		
2JJTC-030-002-6001	1°	60			3	100	6	☑		
2JJTC-030-003-2001	R0,3	1°		20	3	60	6	☑		
2JJTC-030-003-3001		1°		30	3	70	6	☑		
2JJTC-030-003-4001		1°		40	3	80	6	☑		
2JJTC-030-003-5001		1°		50	3	90	6	☑		
2JJTC-030-003-6001		1°		60	3	100	6	☑		
2JJTC-030-005-2001	3	R0,5	1°	20	3	60	6	☑		
2JJTC-030-005-3001			1°	30	3	70	6	☑		
2JJTC-030-005-4001			1°	40	3	80	6	☑		

Objednací číslo	D (mm)	R (mm)	Úhel θ	L2 (mm)	L1 (mm)	L (mm)	d h5 (mm)	Standardní položka
2JJTC-030-005-5001	3	R0,5	1°	50	3	90	6	<input checked="" type="checkbox"/>
2JJTC-030-005-6001			1°	60	3	100	6	<input checked="" type="checkbox"/>
2JJTC-030-010-2001		R1	1°	20	3	60	6	<input checked="" type="checkbox"/>
2JJTC-030-010-3001			1°	30	3	70	6	<input checked="" type="checkbox"/>
2JJTC-030-010-4001			1°	40	3	80	6	<input checked="" type="checkbox"/>
2JJTC-030-010-5001			1°	50	3	90	6	<input checked="" type="checkbox"/>
2JJTC-030-010-6001			1°	60	3	100	6	<input checked="" type="checkbox"/>
2JJTC-040-002-2001			4	R0,2	1°	20	4	60
2JJTC-040-002-3001	1°	30			4	70	6	<input checked="" type="checkbox"/>
2JJTC-040-002-4001	1°	40			4	80	6	<input checked="" type="checkbox"/>
2JJTC-040-002-5001	1°	50			4	90	6	<input checked="" type="checkbox"/>
2JJTC-040-002-6001	1°	60			4	100	6	<input checked="" type="checkbox"/>
2JJTC-040-003-2001	R0,3	1°			20	4	60	6
2JJTC-040-003-3001		1°		30	4	70	6	<input checked="" type="checkbox"/>
2JJTC-040-003-4001		1°		40	4	80	6	<input checked="" type="checkbox"/>
2JJTC-040-003-5001		1°		50	4	90	6	<input checked="" type="checkbox"/>
2JJTC-040-003-6001		1°		60	4	100	6	<input checked="" type="checkbox"/>
2JJTC-040-005-2001		R0,5		1°	20	4	60	6
2JJTC-040-005-3001	1°			30	4	70	6	<input checked="" type="checkbox"/>
2JJTC-040-005-4001	1°			40	4	80	6	<input checked="" type="checkbox"/>
2JJTC-040-005-5001	1°			50	4	90	6	<input checked="" type="checkbox"/>
2JJTC-040-005-6001	1°			60	4	100	6	<input checked="" type="checkbox"/>
2JJTC-040-010-2001	R1			1°	20	4	60	6
2JJTC-040-010-3001		1°		30	4	70	6	<input checked="" type="checkbox"/>
2JJTC-040-010-4001		1°		40	4	80	6	<input checked="" type="checkbox"/>
2JJTC-040-010-5001		1°		50	4	90	6	<input checked="" type="checkbox"/>
2JJTC-040-010-6001		1°		60	4	100	6	<input checked="" type="checkbox"/>

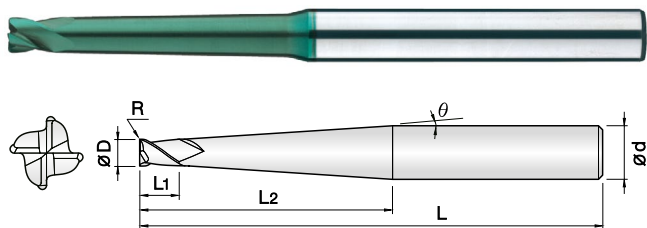

► **Určeno pro kalené oceli (52 - 68 HRC)**

- Vysoká odolnost proti opotřebení díky PVD povlaku na bázi Si
- Velmi přesné tolerance řezných hran
- Široký sortiment rádiusů a vyložení pro optimální výběr nástroje
- Vysoká tuhost díky kuželovému odlehčení
- Vynikající výkon při vysokých řezných rychlostech díky 0,2 μm tvrdokovu



Objednáací číslo	D (mm)	R (mm)	Úhel θ	L2 (mm)	L1 (mm)	L (mm)	d h5 (mm)	Standardní položka		
4JJTC-010-001-0601	1	R0,1	1°	6	1	50	4	☑		
4JJTC-010-001-1001			1°	10	1	50	4	☑		
4JJTC-010-001-1501			1°	15	1	50	4	☑		
4JJTC-010-001-2001			1°	20	1	60	4	☑		
4JJTC-010-001-2501			1°	25	1	60	4	☑		
4JJTC-010-001-3001			1°	30	1	70	4	☑		
4JJTC-010-001-3501			1°	35	1	75	4	☑		
4JJTC-010-002-0601			R0,2	1°	6	1	50	4	☑	
4JJTC-010-002-1001				1°	10	1	50	4	☑	
4JJTC-010-002-1501				1°	15	1	50	4	☑	
4JJTC-010-002-2001				1°	20	1	60	4	☑	
4JJTC-010-002-2501				1°	25	1	60	4	☑	
4JJTC-010-002-3001				1°	30	1	70	4	☑	
4JJTC-010-002-3501				1°	35	1	75	4	☑	
4JJTC-010-003-1001		R0,3		1°	10	1	50	4	☑	
4JJTC-010-003-1501				1°	15	1	50	4	☑	
4JJTC-010-003-2001				1°	20	1	60	4	☑	
4JJTC-010-003-2501				1°	25	1	60	4	☑	
4JJTC-015-002-1001				R0,2	1°	10	1,5	50	4	☑
4JJTC-015-002-1501					1°	15	1,5	50	4	☑
4JJTC-015-002-2001		1°			20	1,5	60	4	☑	
4JJTC-015-002-2501		1°	25		1,5	60	4	☑		
4JJTC-015-002-3001		1°	30		1,5	70	4	☑		
4JJTC-015-002-3501		1°	35		1,5	75	4	☑		
4JJTC-015-003-1501		R0,3	1°		15	1,5	50	4	☑	
4JJTC-015-003-2001			1°		20	1,5	60	4	☑	
4JJTC-015-003-2501			1°		25	1,5	60	4	☑	
4JJTC-015-005-1001			R0,5		1°	10	1,5	50	4	☑
4JJTC-015-005-1501	1°	15			1,5	50	4	☑		
4JJTC-015-005-2001	1°	20			1,5	60	4	☑		
4JJTC-015-005-2501	1°	25			1,5	60	4	☑		
4JJTC-015-005-3001	1°	30			1,5	70	4	☑		
4JJTC-015-005-3501	1°	35		1,5	75	4	☑			
4JJTC-020-002-1201	2	R0,2		1°	12	2	50	4	☑	
4JJTC-020-002-1601				1°	16	2	50	4	☑	
4JJTC-020-002-2001				1°	20	2	60	4	☑	
4JJTC-020-002-2501				1°	25	2	60	4	☑	
4JJTC-020-002-3001			1°	30	2	70	4	☑		
4JJTC-020-002-3501			1°	35	2	75	4	☑		

Objednáací číslo	D (mm)	R (mm)	Úhel θ	L2 (mm)	L1 (mm)	L (mm)	d h5 (mm)	Standardní položka			
4JJTC-020-002-4001	2	R0,2	1°	40	2	80	4	☑			
4JJTC-020-002-5001			1°	50	2	90	4	☑			
4JJTC-020-003-2001			R0,3	1°	20	2	60	4	☑		
4JJTC-020-003-3001				1°	30	2	70	4	☑		
4JJTC-020-003-4001		1°		40	2	80	4	☑			
4JJTC-020-005-1201		R0,5		1°	12	2	50	4	☑		
4JJTC-020-005-1601			1°	16	2	50	4	☑			
4JJTC-020-005-2001			1°	20	2	60	4	☑			
4JJTC-020-005-2501			1°	25	2	60	4	☑			
4JJTC-020-005-3001			R0,5	1°	30	2	70	4	☑		
4JJTC-020-005-3501				1°	35	2	75	4	☑		
4JJTC-020-005-4001				1°	40	2	80	4	☑		
4JJTC-020-005-5001				1°	50	2	90	4	☑		
4JJTC-030-002-2001				3	R0,2	1°	20	3	60	6	☑
4JJTC-030-002-3001						1°	30	3	70	6	☑
4JJTC-030-002-4001		1°	40			3	80	6	☑		
4JJTC-030-002-5001		1°	50			3	90	6	☑		
4JJTC-030-002-6001		1°	60			3	100	6	☑		
4JJTC-030-003-4001		R0,3	1°			40	3	80	6	☑	
4JJTC-030-003-5001			1°		50	3	90	6	☑		
4JJTC-030-003-6001			1°		60	3	100	6	☑		
4JJTC-030-005-2001			R0,5		1°	20	3	60	6	☑	
4JJTC-030-005-3001					1°	30	3	70	6	☑	
4JJTC-030-005-4001					1°	40	3	80	6	☑	
4JJTC-030-005-5001		1°			50	3	90	6	☑		
4JJTC-030-005-6001		1°		60	3	100	6	☑			
4JJTC-040-002-2001		4		R0,2	1°	20	4	60	6	☑	
4JJTC-040-002-3001			1°		30	4	70	6	☑		
4JJTC-040-002-4001	1°		40		4	80	6	☑			
4JJTC-040-002-5001	1°		50		4	90	6	☑			
4JJTC-040-002-6001	1°		60		4	100	6	☑			
4JJTC-040-003-4001	R0,3		1°		40	4	80	6	☑		
4JJTC-040-003-5001			1°		50	4	90	6	☑		
4JJTC-040-003-6001			1°		60	4	100	6	☑		
4JJTC-040-005-2001			R0,5	1°	20	4	60	6	☑		
4JJTC-040-005-3001				1°	30	4	70	6	☑		
4JJTC-040-005-4001				1°	40	4	80	6	☑		
4JJTC-040-005-5001				1°	50	4	90	6	☑		
4JJTC-040-005-6001				1°	60	4	100	6	☑		

▶ 2PHCB 2-břité KULOVÉ frézy ultrapřesné ($R \pm 0,002 - 0,005 \text{ mm}$) pro kalené oceli do HRC 62

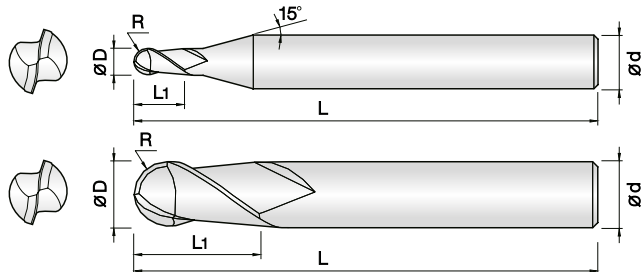

- ▶ Určeno pro kalené oceli (50 - 62 HRC)
- ▶ Vysoká odolnost proti opotřebení díky PVD povlaku na bázi Si
- ▶ Velmi přesné tolerance řezných hran
- ▶ Vysoká kvalita obrobeného povrchu
- ▶ Vynikající výkon při vysokých řezných rychlostech díky 0,2 μm tvrdkovu

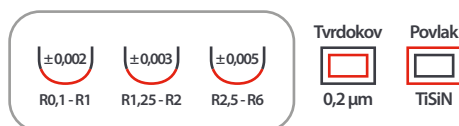
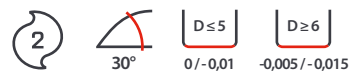

Objednací číslo	D (mm)	R (mm)	L1 (mm)	L (mm)	d h5 (mm)	Standardní položka
2PHCB-002-004-S04	0,2	R0,1	0,4	40	4	☑
2PHCB-003-006-S04	0,3	R0,15	0,6	40	4	☑
2PHCB-004-008-S04	0,4	R0,2	0,8	40	4	☑
2PHCB-005-010-S04	0,5	R0,25	1	45	4	☑
2PHCB-006-012-S04	0,6	R0,3	1,2	45	4	☑
2PHCB-007-015-S04	0,7	R0,35	1,5	45	4	☑
2PHCB-008-020-S04	0,8	R0,4	2	45	4	☑
2PHCB-009-020-S04	0,9	R0,45	2	45	4	☑
2PHCB-010-025-S04	1	R0,5	2,5	50	4	☑
2PHCB-010-025-S06			2,5	50	6	☑
2PHCB-012-030-S04	1,2	R0,6	3	50	4	☑
2PHCB-015-040-S04	1,5	R0,75	4	50	4	☑
2PHCB-015-040-S06			4	50	6	☑
2PHCB-020-050-S04	2	R1	5	50	4	☑
2PHCB-020-050-S06			5	50	6	☑
2PHCB-025-060-S04	2,5	R1,25	6	50	4	☑
2PHCB-030-080-S04	3	R1,5	8	50	4	☑
2PHCB-030-080-S06			8	60	6	☑
2PHCB-035-080-S06	3,5	R1,75	8	60	6	☑
2PHCB-040-080-S04	4	R2	8	60	4	☑
2PHCB-040-080-S06			8	70	6	☑
2PHCB-045-080-S06	4,5	R2,25	8	70	6	☑
2PHCB-050-100-S06	5	R2,5	10	75	6	☑
2PHCB-055-100-S06	5,5	R2,75	10	75	6	☑
2PHCB-060-120-080	6	R3	12	80	6	☑
2PHCB-070-140-S08	7	R3,5	14	80	8	☑
2PHCB-080-140-090	8	R4	14	90	8	☑
2PHCB-100-180-100	10	R5	18	100	10	☑
2PHCB-120-220-110	12	R6	22	110	12	☑



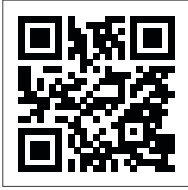

www.powrgrip.cz



powRgrip®

NEJMODERNĚJŠÍ UPÍNÁNÍ ŘEZNÝCH NÁSTROJŮ

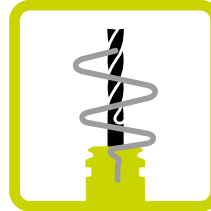

TLUMENÍ VIBRACÍ

- nižší spotřeba nástrojů
- rychlejší obrábění = zvýšení produktivity
- vyšší kvalita povrchu obrobku
- prohlédněte si graf níže



JEDNODUCHOST

- vhodné i pro úplné nováčky
- automatické upnutí nástroje
- žádné nastavování

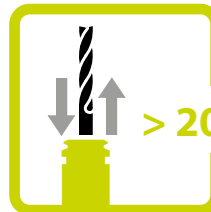

VYSOKÁ ŽIVOTNOST UPÍNAČŮ

> 20 000 x

- stejná přesnost i upínací síla
i po 20 000 upínacích cyklech



MAXIMÁLNÍ UPÍNACÍ SÍLA

- minimalizace vytažení nástroje
z upínače
- provedení secuRgrip = 100%
bezpečnost proti vytažení nástroje

Porovnání TLUMENÍ VIBRACÍ:

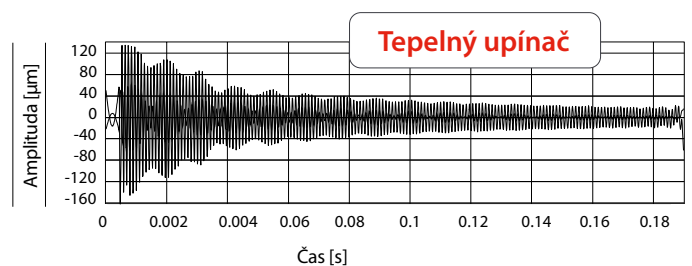
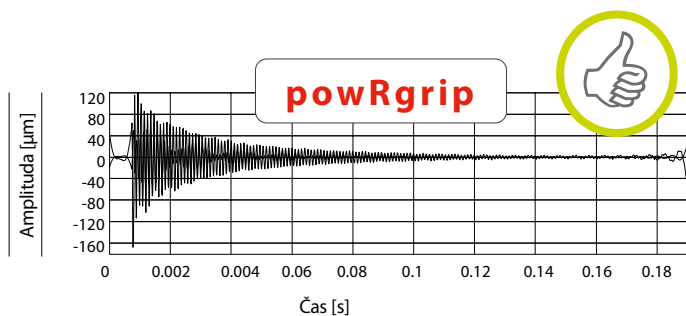

ZDROJ:   Institute for production and high-performance laser technology
Technical University Vienna