

Nouveautés présentées dans ce catalogue
Neuheiten dieses Kataloges
New products introduced in this catalogue



New references		
Type Typ Type	Ref.	Page Seite Page
BH	BHS4-D16-110-F4	10.10
BB-C45	BB4R/L-0612-C45-E03	10.24
	BB4R/L-0714-C45-E03	
	BB4R/L-0918-C45-E05	
	BB4R/L-2575-C45-E05	
	BB4R/L-35105-C45-E05	
BF-C45	BF4R/L-0612-C45-E03	10.25
	BF4R/L-0714-C45-E03	
	BF4R/L-0918-C45-E05	
	BF4R/L-2575-C45-E05	
	BF4R/L-35105-C45-E05	

APPLITEC

BH

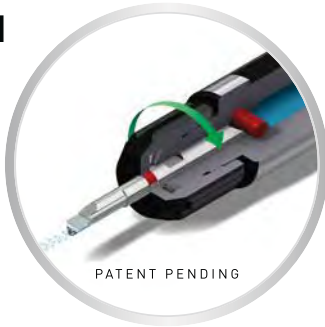

BHS

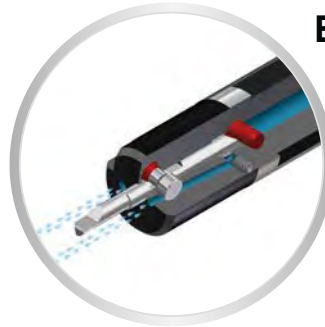



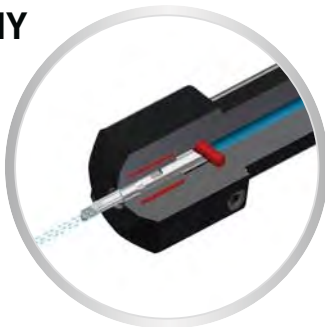

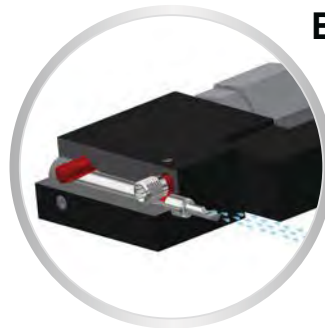

BHY



BHK

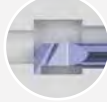
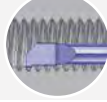
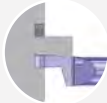

Système de désignation Bezeichnungssystem Designation system	Info		> 10.02
Nuances & paramètres de coupe Sorten & Schnittwerte Grades & machining data			> 10.08
Porte-outils Halter Holders	BH / BHS / BHY / BHK		> 10.10
Alésage Ausbohren Boring	BA / BAX		> 10.18
Alésage-copiage Ausbohren-kopieren Boring chambering	BCX		> 10.22
Copiage Kopieren Chambering	C45 / C45X		> 10.24
Gorge Einstechen Grooving	GX		> 10.28
Fonçage-tournage Einstechen und drehen Grooving and turning	GTX		> 10.30
Filetage Gewindedrehen Threading	TP60° / TP55° / TM		> 10.32
Gorge frontale Axiales Stechen Axial grooving	FEG / FIG	 	> 10.38
Ébauches / Jauges d'alignement / Adaptations machines / Accessoires Rohlinge / Richtplatten / Maschinenanpassungen / Zubehöre Blanks / Adjusting tools / Machines adapters / Accessories			> 10.40



H

HS

HY

B

H

4

-

D

20

-

100

Longueur
Länge
Length

Ø queue
Schaft Ø
Shank Ø

Queue cylindrique
Zylindrischer Schaft
Cylindrical shank

Ø alésage
Bohrung Ø
Bore Ø

Porte-outils
Halter
Holders

Ligne produit d'alésage
Innendreihen Produktlinie
Boring product line

Système de désignation des porte-outils

Halter Bezeichnungssystem

Holders designation system

BHK

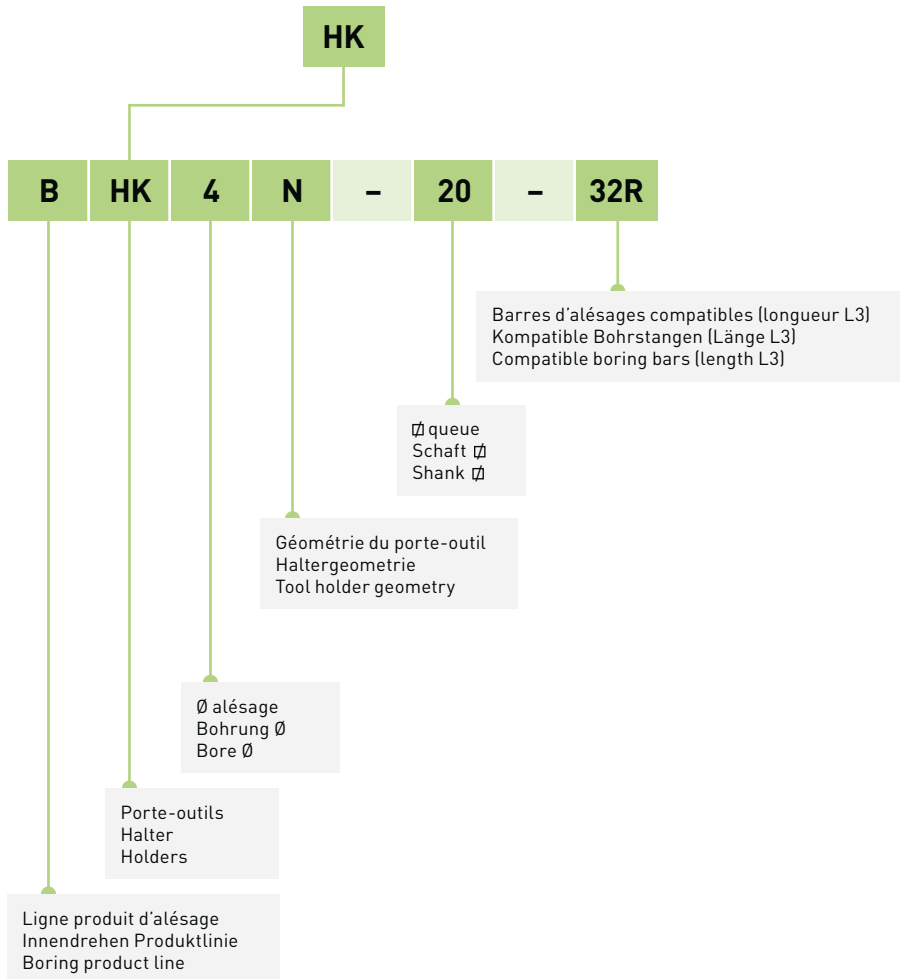
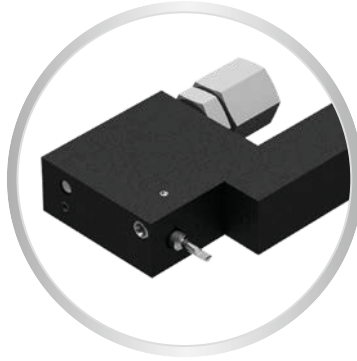

Système de désignation des barres d'alésage

Bohrstangen Bezeichnungssystem

Boring bars designation system

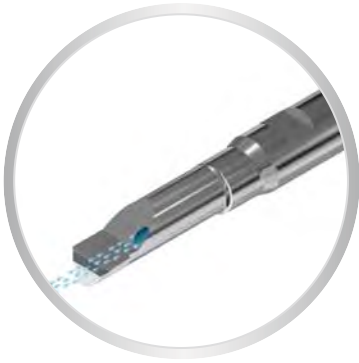

B

F

B B 4 R - 25 - 75 - BAX - R05 - ZN

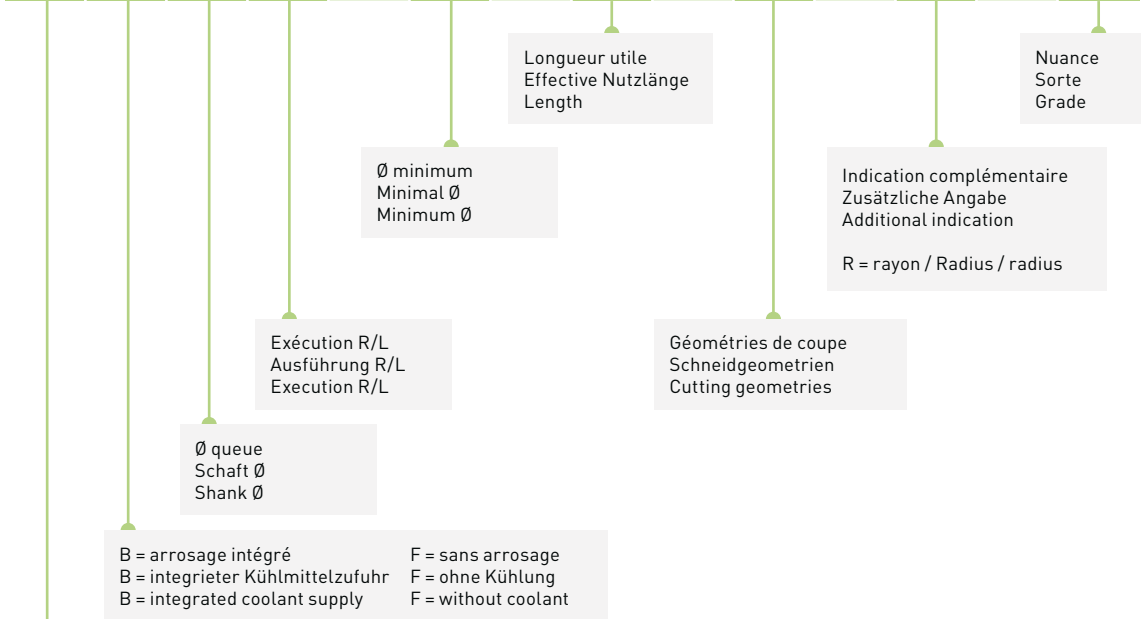

Ligne produit d'alésage
 Innendrehen Produktlinie
 Boring product line

Porte-outils avec écrou de serrage

Halter mit Spannmutter

Tool holders with clamping nut

BH

Arrosage par la barre d'alésage

Kühlung durch die Bohrstange

Cooling through the boring bar

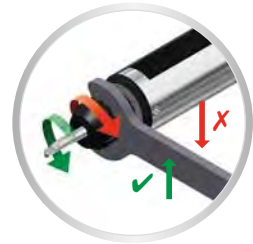

Porte-outils avec arrosage multiple

Halter mit mehrfaches Kühlungssystem

Tool holders with multiple coolant system

BHS

Système de serrage à vis transversale

Querverschraubungssystem

Clamping system with transverse screw



Arrosage sur l'arête de coupe

Kühlung auf der Schneidkante

Cooling on the cutting edge



Arrosage favorisant l'évacuation des copeaux

Spanabfuhr fördernde Kühlung

Cooling for better chip outflow

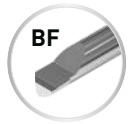

Arrosage par le centre de l'outil

Zentrale Kühlmittelzufuhr

Cooling through the center of the tool



IN-LINE

Porte-outils à serrage hydraulique
Halter mit Hydro-Dehnspann-System
Tool holders with hydraulic clamping system

BHY



Excellente absorption des vibrations!
Ausgezeichnete Schwingungsdämpfung!
Excellent vibration absorbtion!

Arrosage par la barre d'alésage
Kühlung durch die Bohrstange
Cooling through the boring bar

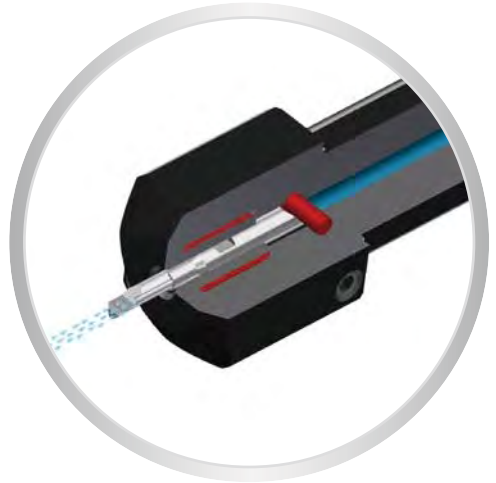

Porte-outils coudés
Gekröpfte Halter
Cranked tool holders

BHK

Système de serrage à vis transversale
Querverschraubungssystem
Clamping system with transverse screw

Arrosage par la barre d'alésage
Kühlung durch die Bohrstange
Cooling through the boring bar

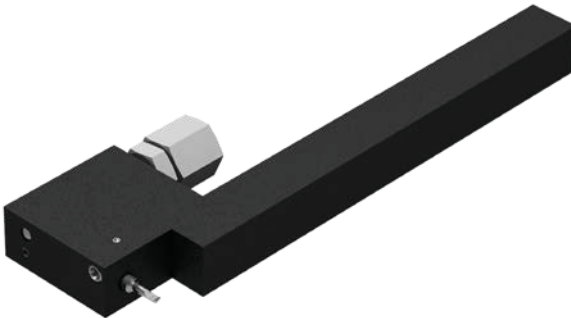

Accessoires de serrage

Spannzubehöre

Clamping accessories

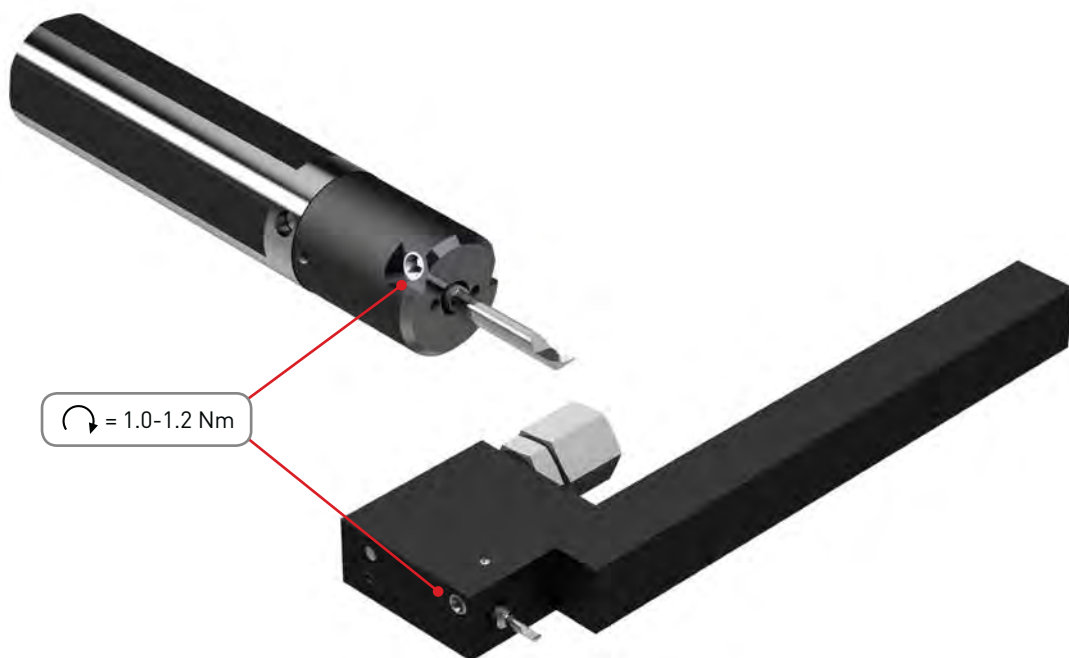

Nous recommandons le serrage des porte-outils types BHS et BHK avec ce type de tournevis dynamométrique.

Wir empfehlen für das Anziehen der Halter Typ BHS und BHK diese Art von Drehmomentschraubendreher.

For holders type BHS and BHK clamping, we recommend this kind of torque screwdriver.



Art. N°

SET-NM1.2-TX8

ZTAF

ZN + revêtement PVD
ZN + PVD Beschichtung
ZN + PVD coating

- nuance universelle pour l'usinage des aciers, aciers inoxydables, aciers alliés, alliage de titane
- bonne résistance à la température

- Universalsorte für die Bearbeitung von Stahl, rostfreiem Stahl, Stahllegierung, Titanlegierung
- gute Warmfestigkeit

- universal grade for steel, stainless steel, alloyed steel, titanium alloys
- good heat resistance

ZTAXF

ZN + revêtement PVD
ZN + PVD Beschichtung
ZN + PVD coating

- nuance très résistante à l'usure et à la température, recommandée pour l'usinage des matières suivantes: Inox 304, 316L, 317L, 904, Phynox
- aciers alliés contenant: Chrome Nickel, Vanadium, Molybdène, ...

- sehr verschleissfeste und temperaturbeständige Sorte. Für folgende Materialien empfohlen: Inox 304, 316L, 317L, 904, Phynox
- legierter Stahl enthaltend: Chrom-Nickel, Vanadium, Molybdän, ...

- very wear and high temperature resistant grade. Recommended for following material: Inox 304, 316L, 317L, 904, Phynox
- alloy steel containing: Chrome-nickel, Vanadium, Molybdenum, ...

ZN

non revêtu
unbeschichtet
uncoated

- nuance de base micro-grain tenace
- 1^{er} choix pour l'usinage des métaux non ferreux

- zähe Basis Feinkornsorte
- beste Wahl für die Bearbeitung von Nichteisenmetalle

- tough base micro-grain grade
- first choice for non-ferrous materials

Paramètres de coupe

Schnittwerte

Machining data

Matière Werkstoff Material	VC (m/min)	Ø barre d'alésage Bohrstange Ø boring bar Ø		
		Ø1.0 - Ø2.0 (mm/U)	Ø2.5 - Ø4.0 (mm/U)	Ø4.5 - Ø5.5 (mm/U)
Acier de décolletage Automatenstahl Free-cutting steel	P 60-100	0.02-0.03	0.02-0.08	0.03-0.10
Acier faiblement allié Leicht legierter Stahl Low alloyed steel	P 50-80	0.01-0.03	0.02-0.05	0.03-0.06
Acier fortement allié Legierter Stahl High alloyed steel	P 40-60	0.01-0.02	0.02-0.04	0.02-0.06
Acier inoxydable Rostfreistahl Stainless steel	M 40-90	0.01-0.03	0.02-0.05	0.03-0.08
Aluminium	N 60-150	0.01-0.03	0.02-0.06	0.03-0.10
Cuivre, laiton, bronze Kupfer, Messing, Bronze Copper, brass, bronze	N 60-150	0.01-0.03	0.02-0.05	0.03-0.08
Titane Titan Titanium	S 30-70	0.01-0.03	0.02-0.05	0.03-0.10

IN-LINE

Porte-outils avec écrou de serrage

Halter mit Spannmutter

Tool holders with clamping nut

BH4...



> page 10.05

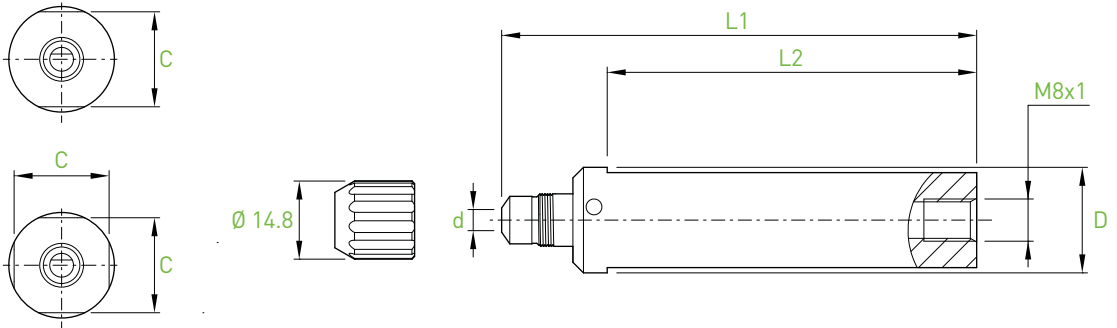

d	Bars	D	L1	L2	C	2 flats	4 flats	Art. N°
4	BB4... BF4...	10	75	55	8.8	■		BH4-D10-75
		12	75	55	11.2	■		BH4-D12-75
		12.7	75	55	11.2	■		BH4-D12.7-75
		15.87	75	55	14	■		BH4-D15.87-75
		16	75	55	14	■		BH4-D16-75
		16	75	55	14		■	BH4-D16-75-F4
		19.05	90	70	17	■		BH4-D19.05-90
		20	90	70	18	■		BH4-D20-90
		20	90	70	18		■	BH4-D20-90-F4
		20	160	140	18		■	BH4-D20-160-F4
		22	90	70	20	■		BH4-D22-90
		22	90	70	20		■	BH4-D22-90-F4
		22	130	110	20		■	BH4-D22-130-F4
		25	100	80	23	■		BH4-D25-100
		25	100	80	23		■	BH4-D25-100-F4
		25	170	150	23		■	BH4-D25-170-F4
25.4	100	80	23.4	■		BH4-D25.4-100		
28	100	80	26	■		BH4-D28-100		

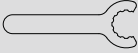
Pièces de rechange Ersatzteile Spare parts		
	Art. N° BH4-M10	Art. N° C-BH4-M10

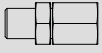
Option	
	Art. N° J-M8x1-D6

Porte-outils avec écrou de serrage

Halter mit Spannmutter

Tool holders with clamping nut

BH6...



> page 10.05

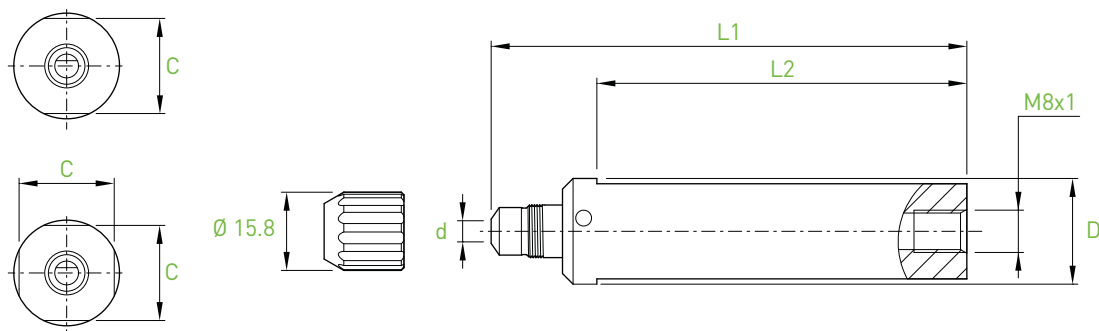

d	Bars	D	L1	L2	C	2 flats	4 flats	Art. N°
6	BH6... BF6...	12	75	55	11.2	■		BH6-D12-75
		12.7	75	55	11.2	■		BH6-D12.7-75
		15.87	75	55	14	■		BH6-D15.87-75
		16	75	55	14	■		BH6-D16-75
		19.05	90	70	17	■		BH6-D19.05-90
		20	90	70	18	■		BH6-D20-90
		20	90	70	18		■	BH6-D20-90-F4
		20	160	140	18		■	BH6-D20-160-F4
		22	90	70	20	■		BH6-D22-90
		22	90	70	20		■	BH6-D22-90-F4
		22	130	110	20		■	BH6-D22-130-F4
		25	100	80	23	■		BH6-D25-100
		25	100	80	23		■	BH6-D25-100-F4
		25	170	150	23		■	BH6-D25-170-F4
		25.4	100	80	23.4	■		BH6-D25.4-100
28	100	80	26	■		BH6-D28-100		

Pièces de rechange
Ersatzteile
Spare parts



Art. N°

BH6...

BH6-M12

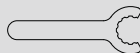

Art. N°

C-BH6-M12

Option



Art. N°

BH6...

J-M8x1-D6

■ = disponible / verfügbar / available

□ = selon disponibilité du stock / jenach Lagerverfügbarkeit / depending the stock availability

Porte-outils avec arrosage multiple
 Halter mit mehrfaches Kühlungssystem
 Tool holders with multiple coolant system

BHS4...



> page 10.05/10.07

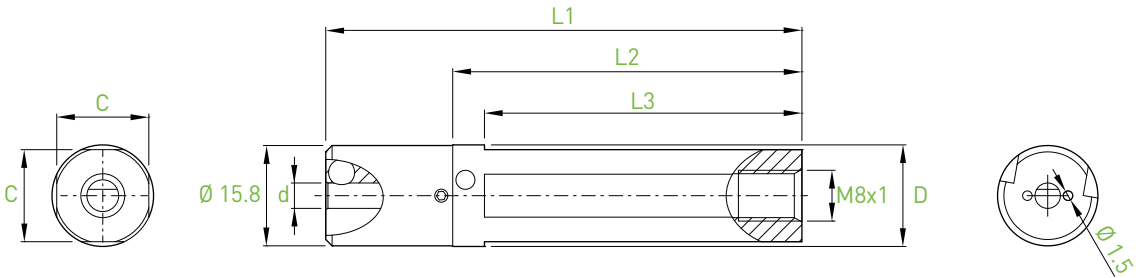

d	Bars	D	L1	L2	L3	C	Art. N°
4	BB4... BF4...	10	75	55	50	9.2	BHS4-D10-75-F4
		12	75	55	50	11	BHS4-D12-75-F4
		12.7	75	55	50	11.7	BHS4-D12.7-75-F4
		15.87	75	55	50	14.5	BHS4-D15.87-75-F4
		16	75	55	50	14.5	BHS4-D16-75-F4
		16	110	90	85	14.5	BHS4-D16-110-F4
		19.05	90	70	65	17	BHS4-D19.05-90-F4
		20	90	70	65	18	BHS4-D20-90-F4
		20	160	140	135	18	BHS4-D20-160-F4
		22	90	70	65	20	BHS4-D22-90-F4
		22	130	110	105	20	BHS4-D22-130-F4
		25	100	80	75	23	BHS4-D25-100-F4
		25	170	150	145	23	BHS4-D25-170-F4
		25.4	100	80	75	23	BHS4-D25.4-100-F4
28	100	80	75	26	BHS4-D28-100-F4		

Pièces de rechange
 Ersatzteile
 Spare parts

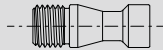

Art. N°

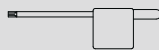

Art. N°

Option

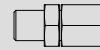

Art. N°

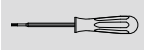

Art. N°

BHS4...

V-BHS-M4x0.5-T8

C-T8

BHS4...

J-M8x1-D6

SET-NM1.2-TX8

Porte-outils avec arrosage multiple
 Halter mit mehrfaches Kühlungssystem
 Tool holders with multiple coolant system

BHS6...



> page 10.05/10.07

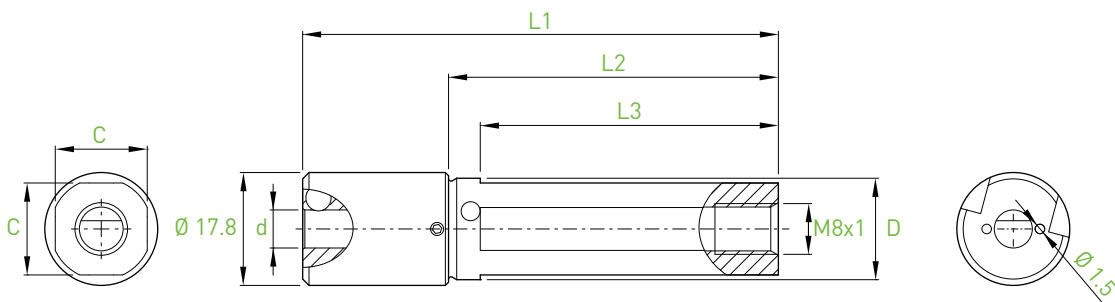

d	Bars	D	L1	L2	L3	C	Art. N°
6	BB6... BF6...	12	75	52	47	11	BHS6-D12-75-F4
		12.7	75	52	47	11.7	BHS6-D12.7-75-F4
		15.87	75	52	47	14.5	BHS6-D15.87-75-F4
		16	75	52	47	14.5	BHS6-D16-75-F4
		16	110	87	82	14.5	BHS6-D16-110-F4
		19.05	90	67	62	17	BHS6-D19.05-90-F4
		20	90	67	62	18	BHS6-D20-90-F4
		20	160	137	132	18	BHS6-D20-160-F4
		22	90	67	62	20	BHS6-D22-90-F4
		22	130	107	102	20	BHS6-D22-130-F4
		25	100	77	72	23	BHS6-D25-100-F4
		25	170	147	142	23	BHS6-D25-170-F4
		25.4	100	77	72	23	BHS6-D25.4-100-F4
28	100	77	72	26	BHS6-D28-100-F4		

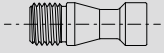
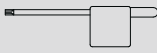
Pièces de rechange Ersatzteile Spare parts		
	Art. N°	Art. N°
BHS6...	V-BHS-M4x0.5-T8	C-T8

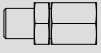
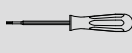
Option		
	Art. N°	Art. N°
BHS6...	J-M8x1-D6	SET-NM1.2-TX8

Porte-outils à serrage hydraulique
 Halter mit Hydro-Dehnspann-System
 Tool holders with hydraulic clamping system

BHY4...

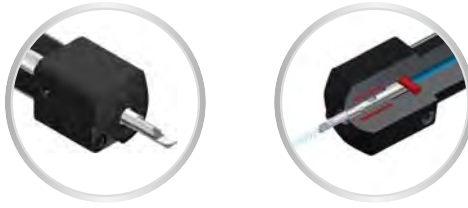

> page 10.06

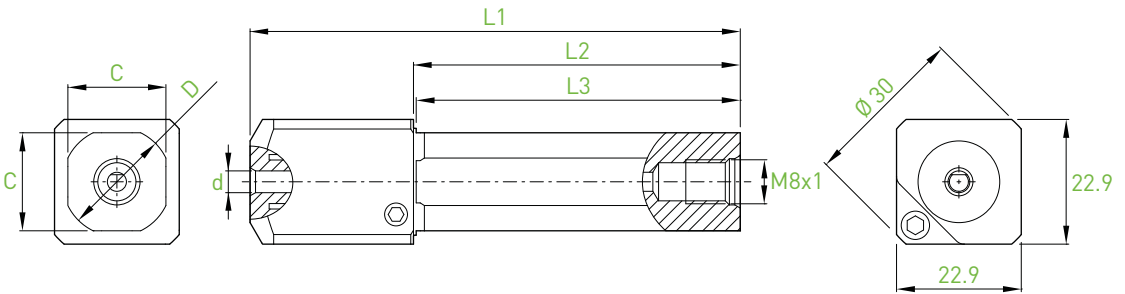

d	Bars	D	L1	L2	L3	C	Art. N°
4	BB4... BF4...	12	90	60	59.5	11.2	BHY4-D12-90-F4
		16	90	60	59.5	14.5	BHY4-D16-90-F4
		19.05	90	60	59.5	17	BHY4-D19.05-90-F4
		20	90	60	59.5	18	BHY4-D20-90-F4
		22	90	60	59.5	20	BHY4-D22-90-F4
		25	100	70	70	23	BHY4-D25-100-F4

Pièces de rechange
 Ersatzteile
 Spare parts

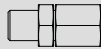

Art. N°

BHY4...

J-M8x1-D6

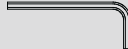

Art. N°

C-6P-3.0

Porte-outils à serrage hydraulique
 Halter mit Hydro-Dehnspann-System
 Tool holders with hydraulic clamping system

BHY6...



> page 10.06

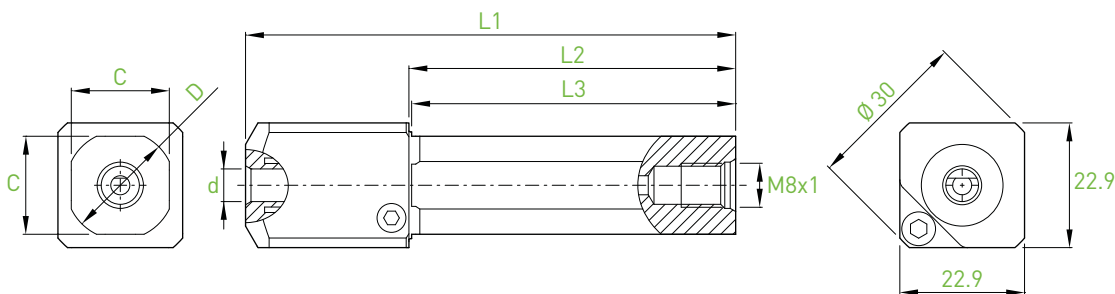

d	Bars	D	L1	L2	L3	C	Art. N°
6	BB6... BF6...	12	90	60	59.5	11.2	BHY6-D12-90-F4
		16	90	60	59.5	14.5	BHY6-D16-90-F4
		19.05	90	60	59.5	17	BHY6-D19.05-90-F4
		20	90	60	59.5	18	BHY6-D20-90-F4
		22	90	60	59.5	20	BHY6-D22-90-F4
		25	100	70	70	23	BHY6-D25-100-F4

Pièces de rechange Ersatzteile Spare parts		
	Art. N°	Art. N°
BHY6...	J-M8x1-D6	C-6P-3.0

> page 10.07

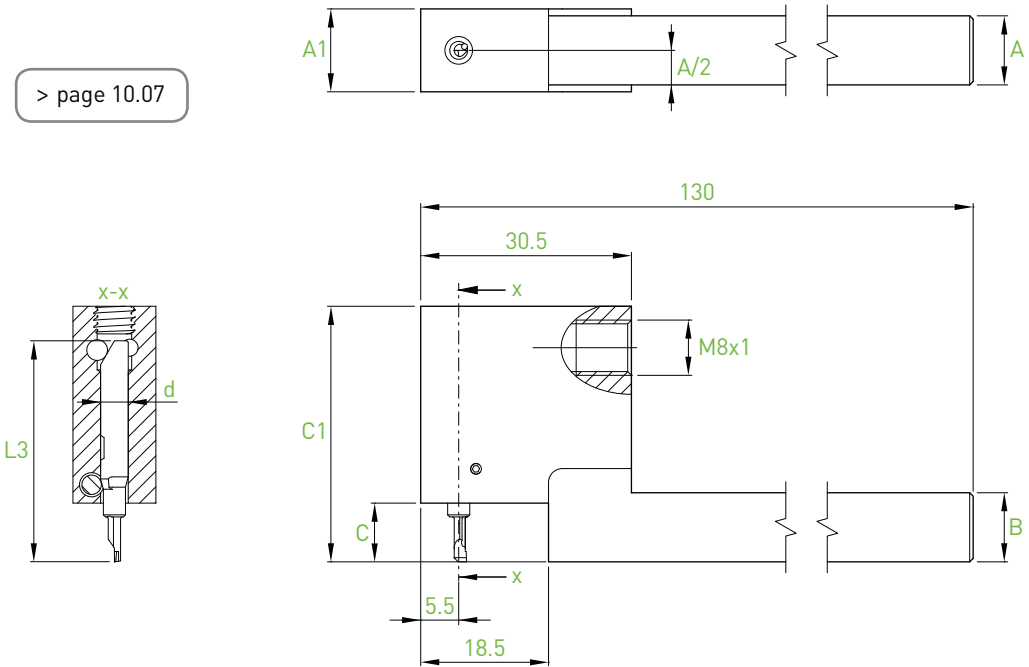

d	Compatible bars L3	A	B	C	C1	A1	Art. N°
4	32	8	8	8.5	37	12	BHK4N-0808X-32R
		10	10	8.5	37	12	BHK4N-1010X-32R
		12	12	8.5	37	12	BHK4N-1212X-32R
		16	16	8.5	37	16	BHK4N-1616X-32R
	37	8	8	13.5	42	12	BHK4N-0808X-37R
		10	10	13.5	42	12	BHK4N-1010X-37R
		12	12	13.5	42	12	BHK4N-1212X-37R
		16	16	13.5	42	16	BHK4N-1616X-37R
	42	10	10	18.5	47	12	BHK4N-1010X-42R
		12	12	18.5	47	12	BHK4N-1212X-42R
		16	16	18.5	47	16	BHK4N-1616X-42R

Pièces de rechange Ersatzteile Spare parts	Art. N°	Art. N°	Option	Art. N°	Art. N°
BHK4N...	V-BHK-M4x0.5-T8	C-T8	BHK4N...	J-M8x1-D6	SET-NM1.2-TX8

Porte-outils coudés

Kröpfunghalter

Cranked tool holders

BHK6N...

> page 10.07

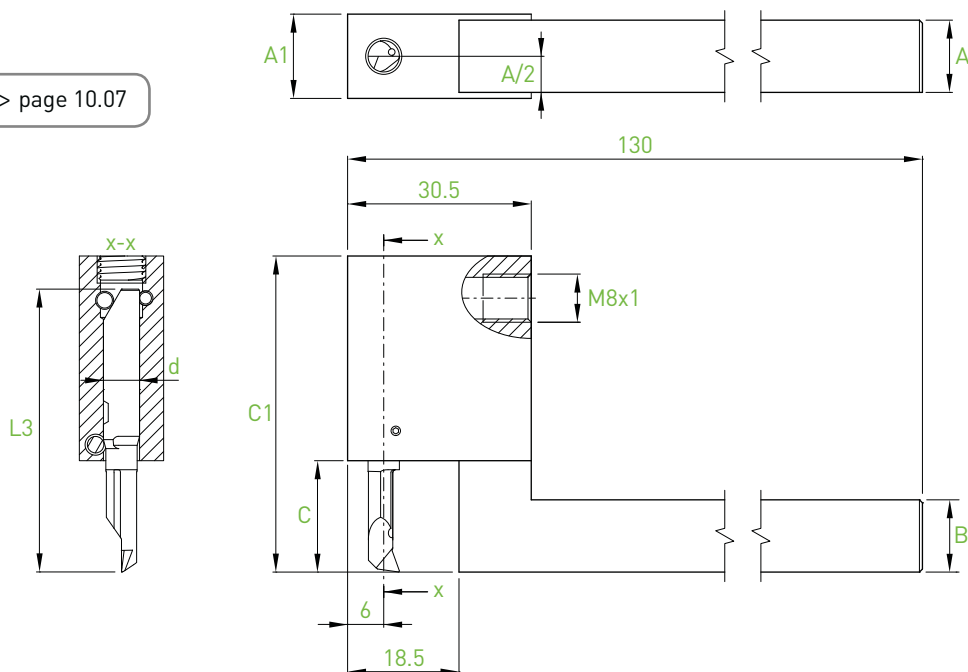

d	Compatible bars L3	A	B	C	C1	A1	Art. N°	
6	BB6R... BF6R...	47	10	10	18.5	52.5	12	BHK6N-1010X-47R
			12	12	18.5	52.5	12	BHK6N-1212X-47R
			16	16	18.5	52.5	16	BHK6N-1616X-47R
		57	10	10	28.5	62.5	12	BHK6N-1010X-57R
			12	12	28.5	62.5	12	BHK6N-1212X-57R
			16	16	28.5	62.5	16	BHK6N-1616X-57R

Pièces de rechange
Ersatzteile
Spare parts

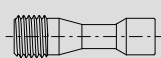

Art. N°

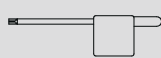

Art. N°

BHK6N...

V-BHK-M4x0.5-T8

C-T8

Option

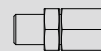

Art. N°



Art. N°

BHK6N...

J-M8x1-D6

SET-NM1.2-TX8

IN-LINE

Alésage
Ausbohren
Boring



BB4...

BA

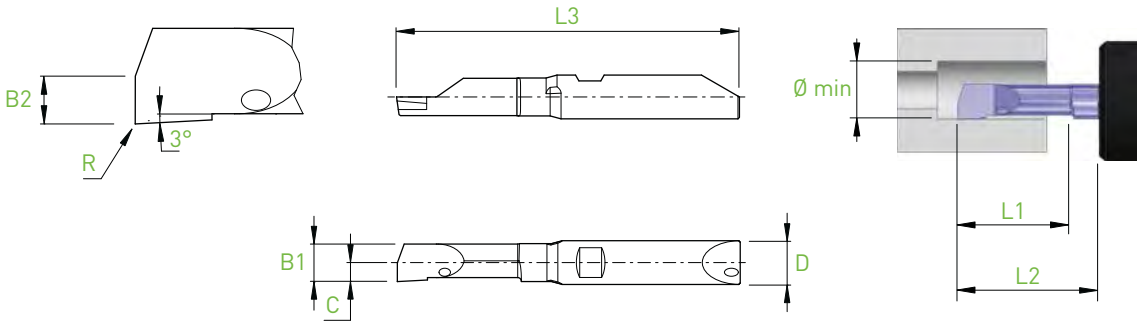

D h5	Holder	Ø min	L1	L2 BH4... BHY4...	L2 BHS4... BHK4...	B1	B2	C	R	L3	Art. N°	R		L		
												ZTAF	ZTAXF	ZN	ZTAF	ZN
4	BH4... BHS4... BHY4... BHK4...	0.3	0.9	10	8.5	0.27	0.13	0.15	0	32	BB4R/L-0309-BA	■	■	■	□	□
		0.4	1.2	10	8.5	0.36	0.18	0.20	0	32	BB4R/L-0412-BA	■	■	■	□	□
		0.5	1.5	10	8.5	0.45	0.22	0.25	0	32	BB4R/L-0515-BA	■	■	■	□	□
		1.0	3.0	10	8.5	0.90	0.45	0.60	0.02	32	BB4R/L-1030-BA-R02	■	■	■	□	□
		1.5	4.5	10	8.5	1.35	0.67	0.65	0.02	32	BB4R/L-1545-BA-R02	■	■	■	□	□
		2.0	6.0	10	8.5	1.80	0.90	1.15	0.02	32	BB4R/L-2060-BA-R02	■	■	■	□	□
		2.5	7.5	10	8.5	2.25	1.13	1.30	0.02	32	BB4R/L-2575-BA-R02	■	■	■	□	□
		3.0	9.0	15	13.5	2.70	1.35	1.35	0.05	37	BB4R/L-3090-BA-R05	■	■	■	□	□
3.5	10.5	15	13.5	3.15	1.58	1.60	0.05	37	BB4R/L-35105-BA-R05	■	■	■	□	□		

Alésage

Ausbohren

Boring



BF4...

BA

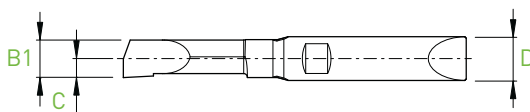
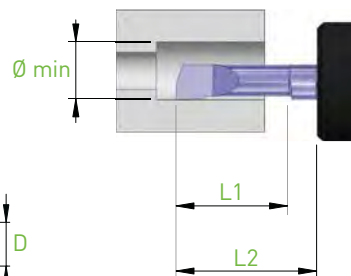
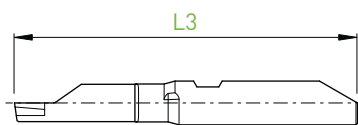
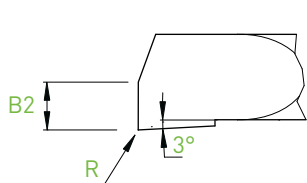

D h5	Holder	Ø min	L1	L2 BH4... BHY4...	L2 BHS4... BHK4...	B1	B2	C	R	L3	Art. N°	R		L		
												ZTAF	ZTAXF	ZN	ZTAF	ZN
4	BH4... BHS4... BHY4... BHK4...	0.3	0.9	10	8.5	0.27	0.13	0.15	0	32	BF4R/L-0309-BA	■	■	■	□	□
		0.4	1.2	10	8.5	0.36	0.18	0.20	0	32	BF4R/L-0412-BA	■	■	■	□	□
		0.5	1.5	10	8.5	0.45	0.22	0.25	0	32	BF4R/L-0515-BA	■	■	■	□	□
		1.0	3.0	10	8.5	0.90	0.45	0.60	0.02	32	BF4R/L-1030-BA-R02	■	■	■	□	□
		1.5	4.5	10	8.5	1.35	0.67	0.65	0.02	32	BF4R/L-1545-BA-R02	■	■	■	□	□
		2.0	6.0	10	8.5	1.80	0.90	1.15	0.02	32	BF4R/L-2060-BA-R02	■	■	■	□	□
		2.5	7.5	10	8.5	2.25	1.13	1.30	0.02	32	BF4R/L-2575-BA-R02	■	■	■	□	□
		3.0	9.0	15	13.5	2.70	1.35	1.35	0.05	37	BF4R/L-3090-BA-R05	■	■	■	□	□
		3.5	10.5	15	13.5	3.15	1.58	1.60	0.05	37	BF4R/L-35105-BA-R05	■	■	■	□	□

Alésage
Ausbohren
Boring



BB4... / BB6...

BAX

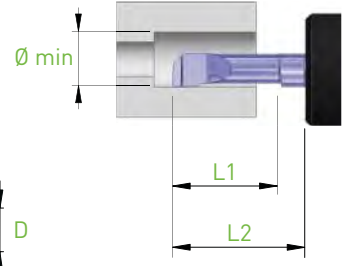
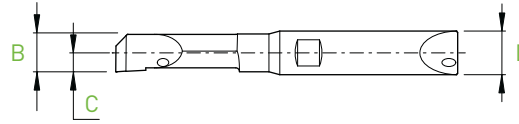
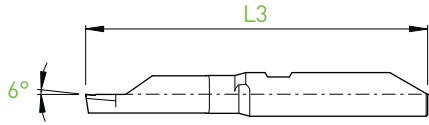
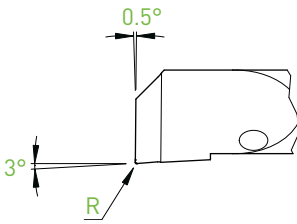

D h5	Holder	Ø min	L1	L2		B	C	R	L3	Art. N°	R		L		
				BH4... BHY4...	BHS4... BHK4...						ZTAF	ZTAXF	ZN	ZTAF	ZN
4	BH4... BHS4... BHY4... BHK4...	0.5	1.5	10	8.5	0.45	0.25	0	32	BB4R/L-0515-BAX	■	■	■	□	□
		0.6	1.8	10	8.5	0.54	0.30	0	32	BB4R/L-0618-BAX	■	■	■	□	□
		0.7	2.1	10	8.5	0.63	0.35	0	32	BB4R/L-0721-BAX	■	■	■	□	□
		0.8	2.4	10	8.5	0.72	0.40	0	32	BB4R/L-0824-BAX	■	■	■	□	□
		0.9	2.7	10	8.5	0.81	0.45	0	32	BB4R/L-0927-BAX	■	■	■	□	□
		1.0	3.0	10	8.5	0.90	0.60	0.02	32	BB4R/L-1030-BAX-R02	■	■	■	□	□
			5.0	10	8.5	0.90	0.60	0.02	32	BB4R/L-1050-BAX-R02	■	■	■	□	□
		1.5	4.5	10	8.5	1.35	0.65	0.02	32	BB4R/L-1545-BAX-R02	■	■	■	□	□
			7.5	10	8.5	1.35	0.65	0.02	32	BB4R/L-1575-BAX-R02	■	■	■	□	□
		2.0	6.0	10	8.5	1.80	1.15	0.02	32	BB4R/L-2060-BAX-R02	■	■	■	□	□
			10.0	15	13.5	1.80	1.15	0.02	37	BB4R/L-20100-BAX-R02	■	■	■	□	□
		2.5	7.5	10	8.5	2.25	1.30	0.05	32	BB4R/L-2575-BAX-R05	■	■	■	□	□
			12.5	15	13.5	2.25	1.30	0.05	37	BB4R/L-25125-BAX-R05	■	■	■	□	□
		3.0	9.0	15	13.5	2.70	1.35	0.05	37	BB4R/L-3090-BAX-R05	■	■	■	□	□
15.0	20		18.5	2.70	1.35	0.05	42	BB4R/L-30150-BAX-R05	■	■	■	□	□		
3.5	10.5	15	13.5	3.15	1.60	0.05	37	BB4R/L-35105-BAX-R05	■	■	■	□	□		
	17.5	20	18.5	3.15	1.60	0.05	42	BB4R/L-35175-BAX-R05	■	■	■	□	□		

D h5	Holder	Ø min	L1	L2		B	C	R	L3	Art. N°	R		L		
				BH6... BHY6...	BHS6... BHK6...						ZTAF	ZTAXF	ZN	ZTAF	ZN
6	BH6... BHS6... BHY6... BHK6...	4.0	12.0	20	18.5	3.80	2.20	0.05	47	BB6R/L-40120-BAX-R05	■	■	■	□	□
			20.0	30	28.5	3.80	2.20	0.05	57	BB6R/L-40200-BAX-R05	■	■	■	□	□
		4.5	13.5	20	18.5	4.28	2.30	0.05	47	BB6R/L-45135-BAX-R05	■	■	■	□	□
			22.5	30	28.5	4.28	2.30	0.05	57	BB6R/L-45225-BAX-R05	■	■	■	□	□
		5.0	15.0	20	18.5	4.75	2.40	0.05	47	BB6R/L-50150-BAX-R05	■	■	■	□	□
			25.0	30	28.5	4.75	2.40	0.05	57	BB6R/L-50250-BAX-R05	■	■	■	□	□
		5.5	16.5	20	18.5	5.15	2.60	0.05	47	BB6R/L-55165-BAX-R05	■	■	■	□	□
			27.5	30	28.5	5.15	2.60	0.05	57	BB6R/L-55275-BAX-R05	■	■	■	□	□

Alésage
Ausbohren
Boring



BF4... / BF6...

BAX

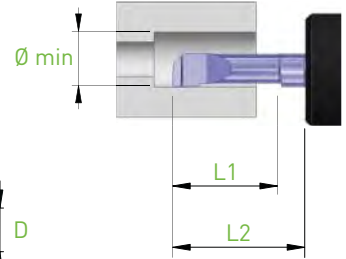
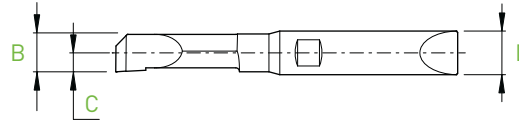
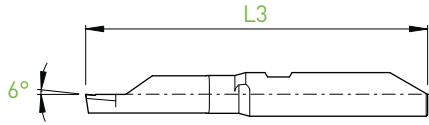
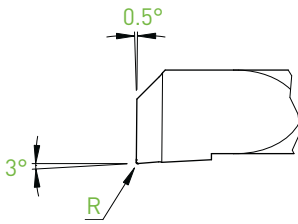

D h5	Holder	Ø min	L1	L2		B	C	R	L3	Art. N°	R		L		
				BH4... BHY4...	BHS4... BHK4...						ZTAF	ZTAXF	ZN	ZTAF	ZN
4	BH4... BHS4... BHY4... BHK4...	0.5	1.5	10	8.5	0.45	0.25	0	32	BF4R/L-0515-BAX	■	■	■	□	□
		0.6	1.8	10	8.5	0.54	0.30	0	32	BF4R/L-0618-BAX	■	■	■	□	□
		0.7	2.1	10	8.5	0.63	0.35	0	32	BF4R/L-0721-BAX	■	■	■	□	□
		0.8	2.4	10	8.5	0.72	0.40	0	32	BF4R/L-0824-BAX	■	■	■	□	□
		0.9	2.7	10	8.5	0.81	0.45	0	32	BF4R/L-0927-BAX	■	■	■	□	□
		1.0	3.0	10	8.5	0.90	0.60	0.02	32	BF4R/L-1030-BAX-R02	■	■	■	□	□
			5.0	10	8.5	0.90	0.60	0.02	32	BF4R/L-1050-BAX-R02	■	■	■	□	□
		1.5	4.5	10	8.5	1.35	0.65	0.02	32	BF4R/L-1545-BAX-R02	■	■	■	□	□
			7.5	10	8.5	1.35	0.65	0.02	32	BF4R/L-1575-BAX-R02	■	■	■	□	□
		2.0	6.0	10	8.5	1.80	1.15	0.02	32	BF4R/L-2060-BAX-R02	■	■	■	□	□
			10.0	15	13.5	1.80	1.15	0.02	37	BF4R/L-20100-BAX-R02	■	■	■	□	□
		2.5	7.5	10	8.5	2.25	1.30	0.05	32	BF4R/L-2575-BAX-R05	■	■	■	□	□
			12.5	15	13.5	2.25	1.30	0.05	37	BF4R/L-25125-BAX-R05	■	■	■	□	□
		3.0	9.0	15	13.5	2.70	1.35	0.05	37	BF4R/L-3090-BAX-R05	■	■	■	□	□
15.0	20		18.5	2.70	1.35	0.05	42	BF4R/L-30150-BAX-R05	■	■	■	□	□		
3.5	10.5	15	13.5	3.15	1.60	0.05	37	BF4R/L-35105-BAX-R05	■	■	■	□	□		
	17.5	20	18.5	3.15	1.60	0.05	42	BF4R/L-35175-BAX-R05	■	■	■	□	□		

D h5	Holder	Ø min	L1	L2		B	C	R	L3	Art. N°	R		L		
				BH6... BHY6...	BHS6... BHK6...						ZTAF	ZTAXF	ZN	ZTAF	ZN
6	BH6... BHS6... BHY6... BHK6...	4.0	12.0	20	18.5	3.80	2.20	0.05	47	BF6R/L-40120-BAX-R05	■	■	■	□	□
			20.0	30	28.5	3.80	2.20	0.05	57	BF6R/L-40200-BAX-R05	■	■	■	□	□
		4.5	13.5	20	18.5	4.28	2.30	0.05	47	BF6R/L-45135-BAX-R05	■	■	■	□	□
			22.5	30	28.5	4.28	2.30	0.05	57	BF6R/L-45225-BAX-R05	■	■	■	□	□
		5.0	15.0	20	18.5	4.75	2.40	0.05	47	BF6R/L-50150-BAX-R05	■	■	■	□	□
			25.0	30	28.5	4.75	2.40	0.05	57	BF6R/L-50250-BAX-R05	■	■	■	□	□
		5.5	16.5	20	18.5	5.15	2.60	0.05	47	BF6R/L-55165-BAX-R05	■	■	■	□	□
			27.5	30	28.5	5.15	2.60	0.05	57	BF6R/L-55275-BAX-R05	■	■	■	□	□

■ = disponible / verfügbar / available
□ = selon disponibilité du stock / jenach Lagerverfügbarkeit / depending the stock availability

IN-LINE

- Alésage-copiage
- Ausbohren-kopieren
- Boring chambering



BB4... / BB6...

BCX

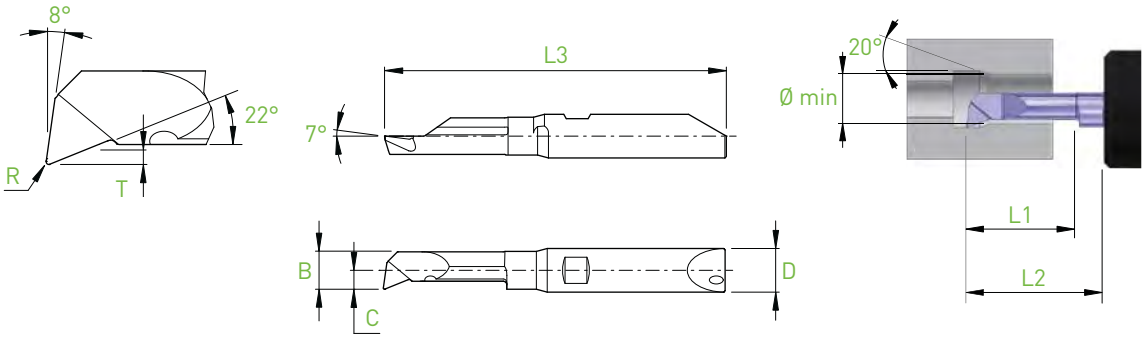

D _{h5}	Holder	Ø min	L1	L2 BH4... BHY4...	L2 BHS4... BHK4...	T	B	C	R	L3	Art. N°	R		L		
												ZTAF	ZTAXF	ZN	ZTAF	ZN
4	BH4... BHS4... BHY4... BHK4...	1.0	3.0	10	8.5	0.15	0.90	0.70	0.05	32	BB4R/L-1030-BCX-R05	■	■	■	□	□
			5.0	10	8.5	0.15	0.90	0.70	0.05	32	BB4R/L-1050-BCX-R05	■	■	■	□	□
		1.5	4.5	10	8.5	0.23	1.35	0.75	0.05	32	BB4R/L-1545-BCX-R05	■	■	■	□	□
			7.5	10	8.5	0.23	1.35	0.75	0.05	32	BB4R/L-1575-BCX-R05	■	■	■	□	□
		2.0	6.0	10	8.5	0.30	1.80	1.15	0.05	32	BB4R/L-2060-BCX-R05	■	■	■	□	□
			10.0	15	13.5	0.30	1.80	1.15	0.05	37	BB4R/L-20100-BCX-R05	■	■	■	□	□
		2.5	7.5	10	8.5	0.38	2.25	1.30	0.10	32	BB4R/L-2575-BCX-R10	■	■	■	□	□
			12.5	15	13.5	0.38	2.25	1.30	0.10	37	BB4R/L-25125-BCX-R10	■	■	■	□	□
		3.0	9.0	15	13.5	0.45	2.70	1.35	0.10	37	BB4R/L-3090-BCX-R10	■	■	■	□	□
			15.0	20	18.5	0.45	2.70	1.35	0.10	42	BB4R/L-30150-BCX-R10	■	■	■	□	□
		3.5	10.5	15	13.5	0.53	3.15	1.60	0.10	37	BB4R/L-35105-BCX-R10	■	■	■	□	□
			17.5	20	18.5	0.53	3.15	1.60	0.10	42	BB4R/L-35175-BCX-R10	■	■	■	□	□
6	BH6... BHS6... BHY6... BHK6...	4.0	12.0	20	18.5	0.60	3.80	2.20	0.15	47	BB6R/L-40120-BCX-R15	■	■	■	□	□
			20.0	30	28.5	0.60	3.80	2.20	0.15	57	BB6R/L-40200-BCX-R15	■	■	■	□	□
		4.5	13.5	20	18.5	0.68	4.28	2.30	0.15	47	BB6R/L-45135-BCX-R15	■	■	■	□	□
			22.5	30	28.5	0.68	4.28	2.30	0.15	57	BB6R/L-45225-BCX-R15	■	■	■	□	□
		5.0	15.0	20	18.5	0.75	4.75	2.40	0.15	47	BB6R/L-50150-BCX-R15	■	■	■	□	□
			25.0	30	28.5	0.75	4.75	2.40	0.15	57	BB6R/L-50250-BCX-R15	■	■	■	□	□
		5.5	16.5	20	18.5	0.83	5.15	2.60	0.15	47	BB6R/L-55165-BCX-R15	■	■	■	□	□
			27.5	30	28.5	0.83	5.15	2.60	0.15	57	BB6R/L-55275-BCX-R15	■	■	■	□	□

Alésage-copiage
 Ausbohren-kopieren
 Boring chambering

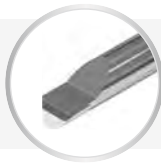

BF4... / BF6...

BCX

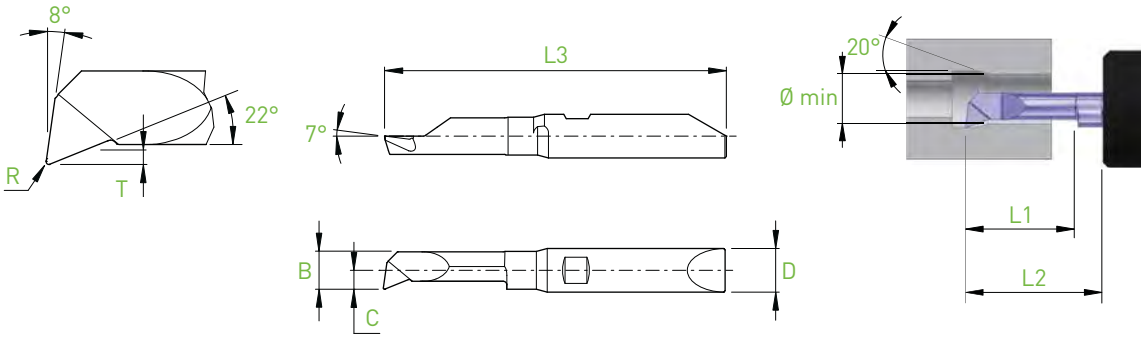

D _{h5}	Holder	Ø min	L1	L2 BH4... BHY4...	L2 BHS4... BHK4...	T	B	C	R	L3	Art. N°	R		L		
												ZTAF	ZTAXF	ZN	ZTAF	ZN
4	BH4... BHS4... BHY4... BHK4...	1.0	3.0	10	8.5	0.15	0.90	0.70	0.05	32	BF4R/L-1030-BCX-R05	■	■	■	□	□
			5.0	10	8.5	0.15	0.90	0.70	0.05	32	BF4R/L-1050-BCX-R05	■	■	■	□	□
		1.5	4.5	10	8.5	0.23	1.35	0.75	0.05	32	BF4R/L-1545-BCX-R05	■	■	■	□	□
			7.5	10	8.5	0.23	1.35	0.75	0.05	32	BF4R/L-1575-BCX-R05	■	■	■	□	□
		2.0	6.0	10	8.5	0.30	1.80	1.15	0.05	32	BF4R/L-2060-BCX-R05	■	■	■	□	□
			10.0	15	13.5	0.30	1.80	1.15	0.05	37	BF4R/L-20100-BCX-R05	■	■	■	□	□
		2.5	7.5	10	8.5	0.38	2.25	1.30	0.10	32	BF4R/L-2575-BCX-R10	■	■	■	□	□
			12.5	15	13.5	0.38	2.25	1.30	0.10	37	BF4R/L-25125-BCX-R10	■	■	■	□	□
		3.0	9.0	15	13.5	0.45	2.70	1.35	0.10	37	BF4R/L-3090-BCX-R10	■	■	■	□	□
			15.0	20	18.5	0.45	2.70	1.35	0.10	42	BF4R/L-30150-BCX-R10	■	■	■	□	□
		3.5	10.5	15	13.5	0.53	3.15	1.60	0.10	37	BF4R/L-35105-BCX-R10	■	■	■	□	□
			17.5	20	18.5	0.53	3.15	1.60	0.10	42	BF4R/L-35175-BCX-R10	■	■	■	□	□

D _{h5}	Holder	Ø min	L1	L2 BH6... BHY6...	L2 BHS6... BHK6...	T	B	C	R	L3	Art. N°	R		L		
												ZTAF	ZTAXF	ZN	ZTAF	ZN
6	BH6... BHS6... BHY6... BHK6...	4.0	12.0	20	18.5	0.60	3.80	2.20	0.15	47	BF6R/L-40120-BCX-R15	■	■	■	□	□
			20.0	30	28.5	0.60	3.80	2.20	0.15	57	BF6R/L-40200-BCX-R15	■	■	■	□	□
		4.5	13.5	20	18.5	0.68	4.28	2.30	0.15	47	BF6R/L-45135-BCX-R15	■	■	■	□	□
			22.5	30	28.5	0.68	4.28	2.30	0.15	57	BF6R/L-45225-BCX-R15	■	■	■	□	□
		5.0	15.0	20	18.5	0.75	4.75	2.40	0.15	47	BF6R/L-50150-BCX-R15	■	■	■	□	□
			25.0	30	28.5	0.75	4.75	2.40	0.15	57	BF6R/L-50250-BCX-R15	■	■	■	□	□
		5.5	16.5	20	18.5	0.83	5.15	2.60	0.15	47	BF6R/L-55165-BCX-R15	■	■	■	□	□
			27.5	30	28.5	0.83	5.15	2.60	0.15	57	BF6R/L-55275-BCX-R15	■	■	■	□	□

■ = disponible / verfügbar / available
 □ = selon disponibilité du stock / jenach Lagerverfügbarkeit / depending the stock availability

Copiage
Kopieren
Chambering



BB4... / BB6...

C45

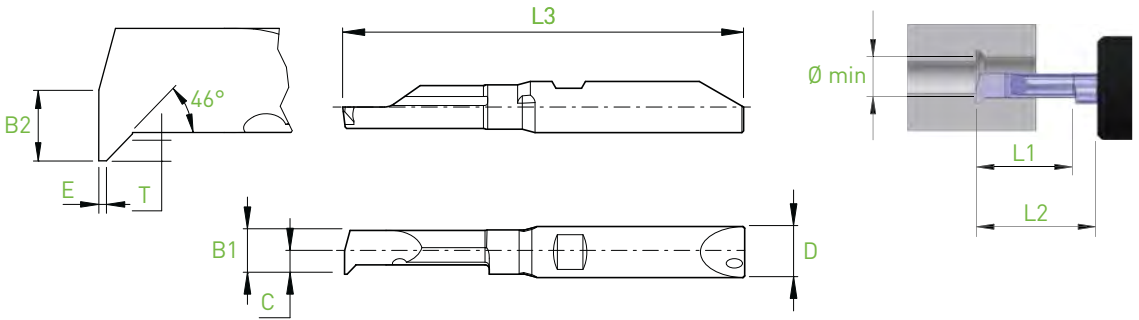

D h5	Holder	Ø min	L1	L2 BH4... BHY4...	L2 BHS4... BHK4...	T	B1	B2	C	E	L3	Art. N°	R		L		
													ZTAF	ZTAXF	ZN	ZTAF	ZN
4	BH4... BHS4... BHY4... BHK4...	0.3	0.6	10	8.5	0.05	0.27	0.13	0.15	0.03	32	BB4R/L-0306-C45-E03	■	■	■	□	□
		0.4	0.8	10	8.5	0.07	0.36	0.18	0.20	0.03	32	BB4R/L-0408-C45-E03	■	■	■	□	□
		0.5	1.0	10	8.5	0.08	0.45	0.22	0.25	0.03	32	BB4R/L-0510-C45-E03	■	■	■	□	□
		0.6	1.2	10	8.5	0.10	0.54	0.27	0.30	0.03	32	BB4R/L-0612-C45-E03	■	■	■	□	□
		0.7	1.2	10	8.5	0.12	0.63	0.32	0.35	0.03	32	BB4R/L-0714-C45-E03	■	■	■	□	□
		0.8	1.6	10	8.5	0.14	0.72	0.36	0.40	0.05	32	BB4R/L-0816-C45-E05	■	■	■	□	□
		0.9	1.8	10	8.5	0.15	0.81	0.41	0.45	0.05	32	BB4R/L-0918-C45-E05	■	■	■	□	□
		1.0	3.0	10	8.5	0.17	0.90	0.45	0.70	0.10	32	BB4R/L-1030-C45-E10	■	■	■	□	□
		1.5	4.5	10	8.5	0.25	1.35	0.67	0.75	0.10	32	BB4R/L-1545-C45-E10	■	■	■	□	□
		2.0	6.0	10	8.5	0.34	1.80	0.90	1.15	0.20	32	BB4R/L-2060-C45-E20	■	■	■	□	□
2.5	7.5	10	8.5	0.43	2.25	1.13	1.30	0.20	32	BB4R/L-2575-C45-E20	■	■	■	□	□		
3.0	9.0	15	13.5	0.51	2.70	1.35	1.35	0.30	37	BB4R/L-3090-C45-E30	■	■	■	□	□		
3.5	10.5	15	13.5	0.60	3.15	1.58	1.60	0.30	37	BB4R/L-35105-C45-E30	■	■	■	□	□		
D h5	Holder	Ø min	L1	L2 BH6... BHY6...	L2 BHS6... BHK6...	T	B1	B2	C	E	L3	Art. N°	ZTAF	ZTAXF	ZN	ZTAF	ZN
6	BH6... BHS6... BHY6... BHK6...	4.0	12.0	20	18.5	0.68	3.80	1.90	2.30	0.40	47	BB6R/L-40120-C45-E40	■	■	■	□	□
		5.0	15.0	20	18.5	0.85	4.75	2.37	2.50	0.50	47	BB6R/L-50150-C45-E50	■	■	■	□	□

Copiage
Kopieren
Chamfering

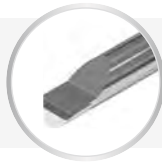

BF4... / BF6...

C45

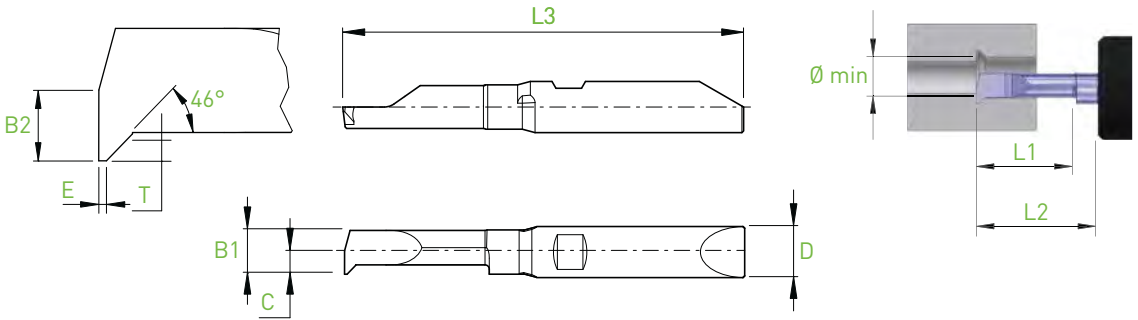

D h5	Holder	Ø min	L1	L2 BH4... BHY4...	L2 BHS4... BHK4...	T	B1	B2	C	E	L3	Art. N°	R		L		
													ZTAF	ZTAXF	ZN	ZTAF	ZN
4	BH4... BHS4... BHY4... BHK4...	0.3	0.6	10	8.5	0.05	0.27	0.13	0.15	0.03	32	BF4R/L-0306-C45-E03	■	■	■	□	□
		0.4	0.8	10	8.5	0.07	0.36	0.18	0.20	0.03	32	BF4R/L-0408-C45-E03	■	■	■	□	□
		0.5	1.0	10	8.5	0.08	0.45	0.22	0.25	0.03	32	BF4R/L-0510-C45-E03	■	■	■	□	□
		0.6	1.2	10	8.5	0.10	0.54	0.27	0.30	0.03	32	BF4R/L-0612-C45-E03	■	■	■	□	□
		0.7	1.2	10	8.5	0.12	0.63	0.32	0.35	0.03	32	BF4R/L-0714-C45-E03	■	■	■	□	□
		0.8	1.6	10	8.5	0.14	0.72	0.36	0.40	0.05	32	BF4R/L-0816-C45-E05	■	■	■	□	□
		0.9	1.8	10	8.5	0.15	0.81	0.41	0.45	0.05	32	BF4R/L-0918-C45-E05	■	■	■	□	□
		1.0	3.0	10	8.5	0.17	0.90	0.45	0.70	0.10	32	BF4R/L-1030-C45-E10	■	■	■	□	□
		1.5	4.5	10	8.5	0.25	1.35	0.67	0.75	0.10	32	BF4R/L-1545-C45-E10	■	■	■	□	□
		2.0	6.0	10	8.5	0.34	1.80	0.90	1.15	0.20	32	BF4R/L-2060-C45-E20	■	■	■	□	□
2.5	7.5	10	8.5	0.43	2.25	1.13	1.30	0.20	32	BF4R/L-2575-C45-E20	■	■	■	□	□		
3.0	9.0	15	13.5	0.51	2.70	1.35	1.35	0.30	37	BF4R/L-3090-C45-E30	■	■	■	□	□		
3.5	10.5	15	13.5	0.60	3.15	1.58	1.60	0.30	37	BF4R/L-35105-C45-E30	■	■	■	□	□		
D h5	Holder	Ø min	L1	L2 BH6... BHY6...	L2 BHS6... BHK6...	T	B1	B2	C	E	L3	Art. N°	ZTAF	ZTAXF	ZN	ZTAF	ZN
6	BH6... BHS6... BHY6... BHK6...	4.0	12.0	20	18.5	0.68	3.80	1.90	2.30	0.40	47	BF6R/L-40120-C45-E40	■	■	■	□	□
		5.0	15.0	20	18.5	0.85	4.75	2.37	2.50	0.50	47	BF6R/L-50150-C45-E50	■	■	■	□	□

■ = disponible / verfügbar / available
□ = selon disponibilité du stock / jenach Lagerverfügbarkeit / depending the stock availability

- Copiage**
- Kopieren**
- Chambering**



BB4... / BB6...

C45X

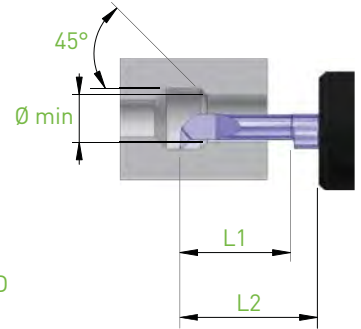
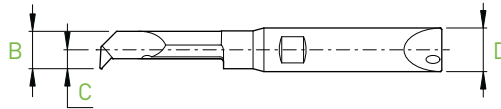
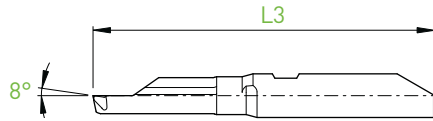
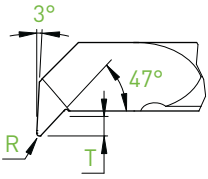

D h5	Holder	Ø min	L1	L2 BH4... BHY4...	L2 BHS4... BHK4...	T	B	C	R	L3	Art. N°	R		L		
												ZTAF	ZTAXF	ZN	ZTAF	ZN
4	BH4... BHS4... BHY4... BHK4...	2.5	7.5	10	8.5	0.50	2.25	1.35	0.10	32	BB4R/L-2575-C45X-R10	■	■	■	□	□
			12.5	15	13.5	0.50	2.25	1.35	0.10	37	BB4R/L-25125-C45X-R10	■	■	■	□	□
		3.0	9.0	15	13.5	0.60	2.70	1.45	0.10	37	BB4R/L-3090-C45X-R10	■	■	■	□	□
			15.0	20	18.5	0.60	2.70	1.45	0.10	42	BB4R/L-30150-C45X-R10	■	■	■	□	□
		3.5	10.5	15	13.5	0.70	3.15	1.60	0.10	37	BB4R/L-35105-C45X-R10	■	■	■	□	□
			17.5	20	18.5	0.70	3.15	1.60	0.10	42	BB4R/L-35175-C45X-R10	■	■	■	□	□
D h5	Holder	Ø min	L1	L2 BH6... BHY6...	L2 BHS6... BHK6...	T	B	C	R	L3	Art. N°	ZTAF	ZTAXF	ZN	ZTAF	ZN
6	BH6... BHS6... BHY6... BHK6...	4.0	12.0	20	18.5	0.80	3.80	2.30	0.15	47	BB6R/L-40120-C45X-R15	■	■	■	□	□
			20.0	30	28.5	0.80	3.80	2.30	0.15	57	BB6R/L-40200-C45X-R15	■	■	■	□	□
		4.5	13.5	20	18.5	0.90	4.28	2.40	0.15	47	BB6R/L-45135-C45X-R15	■	■	■	□	□
			22.5	30	28.5	0.90	4.28	2.40	0.15	57	BB6R/L-45225-C45X-R15	■	■	■	□	□
		5.0	15.0	20	18.5	1.00	4.75	2.50	0.15	47	BB6R/L-50150-C45X-R15	■	■	■	□	□
			25.0	30	28.5	1.00	4.75	2.50	0.15	57	BB6R/L-50250-C45X-R15	■	■	■	□	□
		5.5	16.5	20	18.5	1.10	5.15	2.60	0.15	47	BB6R/L-55165-C45X-R15	■	■	■	□	□
			27.5	30	28.5	1.10	5.15	2.60	0.15	57	BB6R/L-55275-C45X-R15	■	■	■	□	□

Copiage
Kopieren
Chambering



BF4... / BF6...

C45X

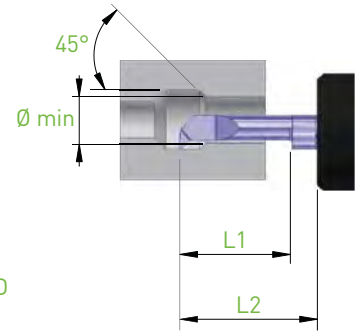
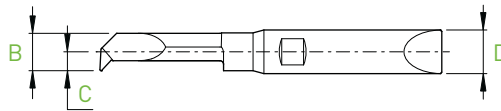
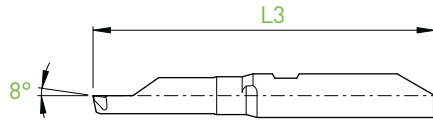
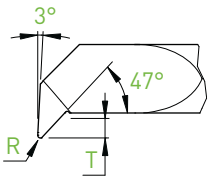

D h5	Holder	Ø min	L1	L2 BH4... BHY4...	L2 BHS4... BHK4...	T	B	C	R	L3	Art. N°	R		L		
												ZTAF	ZTAXF	ZN	ZTAF	ZN
4	BH4... BHS4... BHY4... BHK4...	2.5	7.5	10	8.5	0.50	2.25	1.35	0.10	32	BF4R/L-2575-C45X-R10	■	■	■	□	□
			12.5	15	13.5	0.50	2.25	1.35	0.10	37	BF4R/L-25125-C45X-R10	■	■	■	□	□
		3.0	9.0	15	13.5	0.60	2.70	1.45	0.10	37	BF4R/L-3090-C45X-R10	■	■	■	□	□
			15.0	20	18.5	0.60	2.70	1.45	0.10	42	BF4R/L-30150-C45X-R10	■	■	■	□	□
		3.5	10.5	15	13.5	0.70	3.15	1.60	0.10	37	BF4R/L-35105-C45X-R10	■	■	■	□	□
			17.5	20	18.5	0.70	3.15	1.60	0.10	42	BF4R/L-35175-C45X-R10	■	■	■	□	□
D h5	Holder	Ø min	L1	L2 BH6... BHY6...	L2 BHS6... BHK6...	T	B	C	R	L3	Art. N°	ZTAF	ZTAXF	ZN	ZTAF	ZN
6	BH6... BHS6... BHY6... BHK6...	4.0	12.0	20	18.5	0.80	3.80	2.30	0.15	47	BF6R/L-40120-C45X-R15	■	■	■	□	□
			20.0	30	28.5	0.80	3.80	2.30	0.15	57	BF6R/L-40200-C45X-R15	■	■	■	□	□
		4.5	13.5	20	18.5	0.90	4.28	2.40	0.15	47	BF6R/L-45135-C45X-R15	■	■	■	□	□
			22.5	30	28.5	0.90	4.28	2.40	0.15	57	BF6R/L-45225-C45X-R15	■	■	■	□	□
		5.0	15.0	20	18.5	1.00	4.75	2.50	0.15	47	BF6R/L-50150-C45X-R15	■	■	■	□	□
			25.0	30	28.5	1.00	4.75	2.50	0.15	57	BF6R/L-50250-C45X-R15	■	■	■	□	□
		5.5	16.5	20	18.5	1.10	5.15	2.60	0.15	47	BF6R/L-55165-C45X-R15	■	■	■	□	□
			27.5	30	28.5	1.10	5.15	2.60	0.15	57	BF6R/L-55275-C45X-R15	■	■	■	□	□

■ = disponible / verfügbar / available
□ = selon disponibilité du stock / jenach Lagerverfügbarkeit / depending the stock availability

Gorge
Einstecken
Grooving



BB4... / BB6...

GX

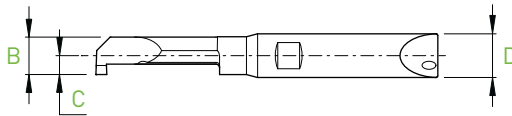
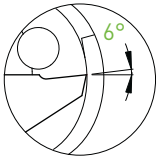
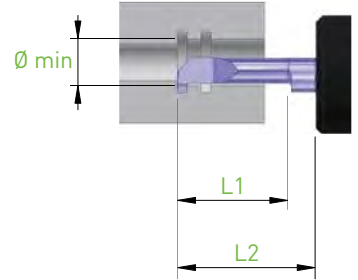
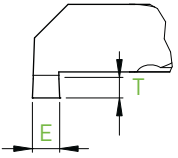

D h5	Holder	Ø min	L1	L2		E	T	B	C	L3	Art. N°	R		L		
				BH4... BHY4...	BHS4... BHK4...							ZTAF ZN	ZTAXF ZN			
4	BH4... BHS4... BHY4... BHK4...	3.0	9.0	15	13.5	0.50	0.60	2.70	1.45	37	BB4R/L-3090-G050X	■	■	■	□	□
			15.0	20	18.5	0.50	0.60	2.70	1.45	42	BB4R/L-30150-G050X	■	■	■	□	□
	3.5	10.5	15	13.5	0.75	0.70	3.15	1.60	37	BB4R/L-35105-G075X	■	■	■	□	□	
		17.5	20	18.5	0.75	0.70	3.15	1.60	42	BB4R/L-35175-G075X	■	■	■	□	□	

D h5	Holder	Ø min	L1	L2		E	T	B	C	L3	Art. N°	R		L			
				BH6... BHY6...	BHS6... BHK6...							ZTAF ZN	ZTAXF ZN				
6	BH6... BHS6... BHY6... BHK6...	4.0	12.0	20	18.5	1.00	0.80	3.80	2.20	47	BB6R/L-40120-G100X	■	■	■	□	□	
			20.0	30	28.5	1.00	0.80	3.80	2.20	57	BB6R/L-40200-G100X	■	■	■	□	□	
		4.5	13.5	20	18.5	1.00	0.90	4.28	2.40	47	BB6R/L-45135-G100X	■	■	■	□	□	
						1.50					BB6R/L-45135-G150X	■	■	■	□	□	
		22.5	30	28.5	1.00	0.90	4.28	2.40	57	BB6R/L-45225-G100X	■	■	■	□	□		
					1.50					BB6R/L-45225-G150X	■	■	■	□	□		
		5.0	15.0	20	18.5	1.00	1.00	4.75	2.50	47	BB6R/L-50150-G100X	■	■	■	□	□	
						1.50					BB6R/L-50150-G150X	■	■	■	□	□	
			25.0	30	28.5	1.00	1.00	4.75	2.50	57	BB6R/L-50250-G100X	■	■	■	□	□	
						1.50					BB6R/L-50250-G150X	■	■	■	□	□	
		5.5	16.5	20	18.5	1.00	1.10	5.15	2.60	47	BB6R/L-55165-G100X	■	■	■	□	□	
						1.50					BB6R/L-55165-G150X	■	■	■	□	□	
			2.00	27.5	30	28.5	1.00	1.10	5.15	2.60	57	BB6R/L-55275-G100X	■	■	■	□	□
							1.50					BB6R/L-55275-G150X	■	■	■	□	□
			2.00	27.5	30	28.5	1.50	1.10	5.15	2.60	57	BB6R/L-55275-G200X	■	■	■	□	□
							2.00					BB6R/L-55275-G200X	■	■	■	□	□

Gorge
Einstecken
Grooving



BF4... / BF6...

GX

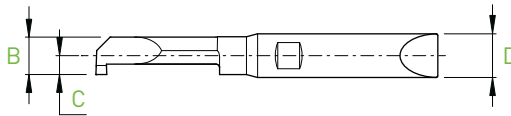
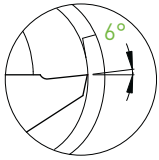
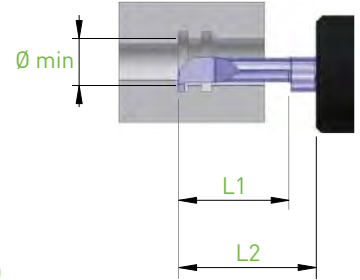
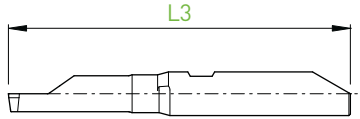
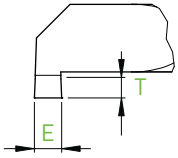

D h5	Holder	Ø min	L1	L2		E	T	B	C	L3	Art. N°	R		L		
				BH4... BHY4...	BHS4... BHK4...							ZTAF	ZTAXF	ZN	ZTAF	ZN
4	BH4... BHS4... BHY4... BHK4...	3.0	9.0	15	13.5	0.50	0.60	2.70	1.45	37	BF4R/L-3090-G050X	■	■	■	□	□
			15.0	20	18.5	0.50	0.60	2.70	1.45	42	BF4R/L-30150-G050X	■	■	■	□	□
	3.5	10.5	15	13.5	0.75	0.70	3.15	1.60	37	BF4R/L-35105-G075X	■	■	■	□	□	
		17.5	20	18.5	0.75	0.70	3.15	1.60	42	BF4R/L-35175-G075X	■	■	■	□	□	
D h5	Holder	Ø min	L1	L2		E	T	B	C	L3	Art. N°	R		L		
6	BH6... BHS6... BHY6... BHK6...	4.0	12.0	20	18.5							1.00	0.80	3.80	2.20	47
			20.0	30	28.5	1.00	0.80	3.80	2.20	57	BF6R/L-40200-G100X	■	■	■	□	□
		4.5	13.5	20	18.5	1.00	0.90	4.28	2.40	47	BF6R/L-45135-G100X	■	■	■	□	□
						1.50					BF6R/L-45135-G150X	■	■	■	□	□
		5.0	15.0	20	18.5	1.00	1.00	4.75	2.50	47	BF6R/L-45225-G100X	■	■	■	□	□
						1.50					BF6R/L-45225-G150X	■	■	■	□	□
		5.5	16.5	20	18.5	1.00	1.10	5.15	2.60	47	BF6R/L-50150-G100X	■	■	■	□	□
						1.50					BF6R/L-50150-G150X	■	■	■	□	□
			25.0	30	28.5	1.00	1.00	4.75	2.50	57	BF6R/L-50250-G100X	■	■	■	□	□
						1.50					BF6R/L-50250-G150X	■	■	■	□	□
			27.5	30	28.5	1.00	1.10	5.15	2.60	57	BF6R/L-55165-G100X	■	■	■	□	□
						1.50					BF6R/L-55165-G150X	■	■	■	□	□
						2.00					BF6R/L-55165-G200X	■	■	■	□	□
						1.00					BF6R/L-55275-G100X	■	■	■	□	□
		1.50	1.10	5.15	2.60	57	BF6R/L-55275-G150X	■	■	■	□	□				
							2.00	BF6R/L-55275-G200X	■	■	■	□	□			

■ = disponible / verfügbar / available
□ = selon disponibilité du stock / jenach Lagerverfügbarkeit / depending the stock availability

IN-LINE

Fonçage-tournage
Einstecken und drehen
Grooving and turning



BB4... / BB6...

GTX

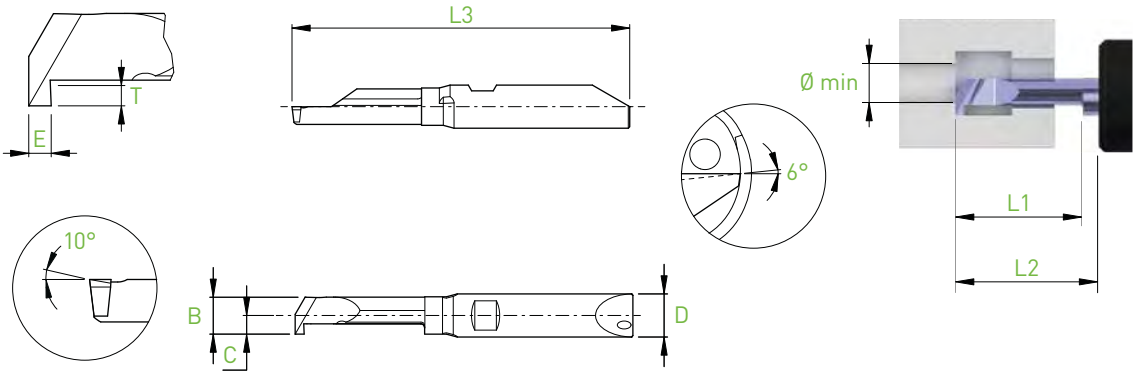

D h5	Holder	Ø min	L1	L2 BH4... BHY4...	L2 BHS4... BHK4...	E	T	B	C	L3	Art. N°	R		L		
												ZTAF	ZTAXF	ZN	ZTAF	ZN
4	BH4... BHS4... BHY4... BHK4...	3.0	9.0	15	13.5	1.00	0.60	2.7	1.45	37	BB4R/L-3090-GT100X	■	■	■	□	□
			15.0	20	18.5	1.00	0.60	2.7	1.45	42	BB4R/L-30150-GT100X	■	■	■	□	□
	3.5	10.5	15	13.5	1.00	0.70	3.15	1.6	37	BB4R/L-35105-GT100X	■	■	■	□	□	
		17.5	20	18.5	1.00	0.70	3.15	1.6	42	BB4R/L-35175-GT100X	■	■	■	□	□	
D h5	Holder	Ø min	L1	L2 BH6... BHY6...	L2 BHS6... BHK6...	E	T	B	C	L3	Art. N°	ZTAF	ZTAXF	ZN	ZTAF	ZN
6	BH6... BHS6... BHY6... BHK6...	4.0	14.0	20	18.5	1.25	0.80	3.8	2.2	47	BB6R/L-40140-GT125X	■	■	■	□	□
			22.0	30	28.5	1.25	0.80	3.8	2.2	57	BB6R/L-40220-GT125X	■	■	■	□	□
		4.5	16.0	20	18.5	1.25	0.90	4.28	2.4	47	BB6R/L-45160-GT125X	■	■	■	□	□
			25.0	30	28.5	1.25	0.90	4.28	2.4	57	BB6R/L-45250-GT125X	■	■	■	□	□
		5.0	17.5	20	18.5	1.25	1.00	4.75	2.5	47	BB6R/L-50175-GT125X	■	■	■	□	□
			27.5	30	28.5	1.25	1.00	4.75	2.5	57	BB6R/L-50275-GT125X	■	■	■	□	□
		5.5	17.5	20	18.5	1.25	1.10	5.15	2.6	47	BB6R/L-55175-GT125X	■	■	■	□	□
			27.5	30	28.5	1.25	1.10	5.15	2.6	57	BB6R/L-55275-GT125X	■	■	■	□	□

Fonçage-tournage

Einstechen und drehen

Grooving and turning



BF4... / BF6...

GTX

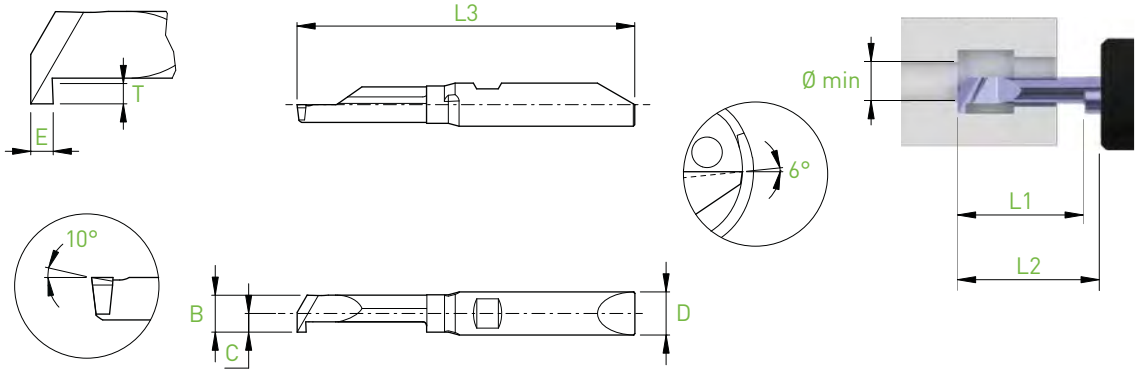

D h5	Holder	Ø min	L1	L2 BH4... BHY4...	L2 BHS4... BHK4...	E	T	B	C	L3	Art. N°	R		L		
												ZTAF	ZTAXF	ZN	ZTAF	ZN
4	BH4... BHS4... BHY4... BHK4...	3.0	9.0	15	13.5	1.00	0.60	2.7	1.45	37	BF4R/L-3090-GT100X	■	■	■	□	□
			15.0	20	18.5	1.00	0.60	2.7	1.45	42	BF4R/L-30150-GT100X	■	■	■	□	□
	3.5	10.5	15	13.5	1.00	0.70	3.15	1.6	37	BF4R/L-35105-GT100X	■	■	■	□	□	
		17.5	20	18.5	1.00	0.70	3.15	1.6	42	BF4R/L-35175-GT100X	■	■	■	□	□	
D h5	Holder	Ø min	L1	L2 BH6... BHY6...	L2 BHS6... BHK6...	E	T	B	C	L3	Art. N°	ZTAF	ZTAXF	ZN	ZTAF	ZN
6	BH6... BHS6... BHY6... BHK6...	4.0	14.0	20	18.5	1.25	0.80	3.8	2.2	47	BF6R/L-40140-GT125X	■	■	■	□	□
			22.0	30	28.5	1.25	0.80	3.8	2.2	57	BF6R/L-40220-GT125X	■	■	■	□	□
		4.5	16.0	20	18.5	1.25	0.90	4.28	2.4	47	BF6R/L-45160-GT125X	■	■	■	□	□
			25.0	30	28.5	1.25	0.90	4.28	2.4	57	BF6R/L-45250-GT125X	■	■	■	□	□
		5.0	17.5	20	18.5	1.25	1.00	4.75	2.5	47	BF6R/L-50175-GT125X	■	■	■	□	□
			27.5	30	28.5	1.25	1.00	4.75	2.5	57	BF6R/L-50275-GT125X	■	■	■	□	□
		5.5	17.5	20	18.5	1.25	1.10	5.15	2.6	47	BF6R/L-55175-GT125X	■	■	■	□	□
			27.5	30	28.5	1.25	1.10	5.15	2.6	57	BF6R/L-55275-GT125X	■	■	■	□	□

■ = disponible / verfügbar / available

□ = selon disponibilité du stock / jenach Lagerverfügbarkeit / depending the stock availability

IN-LINE

Filetage
Gewindedrehen
Threading



BB4... / BB6...

TP60

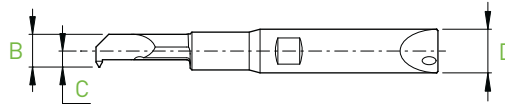
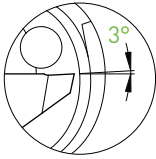
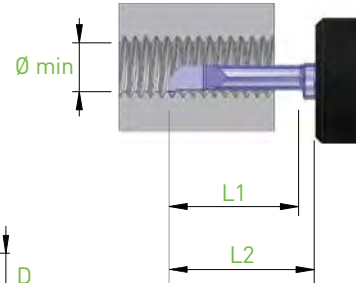
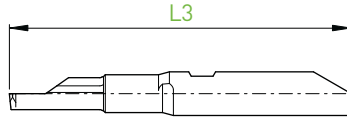
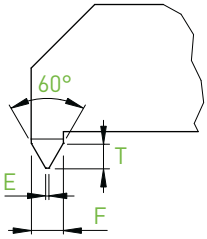

D h5	Holder	Ø min	L1	L2 BH4... BHY4...	L2 BHS4... BHK4...	P (mm)	P (TPI)	F	E (0/-0.01)	T	B	C	L3	Art. N°	R		L	
															ZTAF ZN	ZTAF ZN		
4	BH4... BHS4... BHY4... BHK4...	1.25	3.2	10	8.5	0.20-0.35	80	0.30	0.02	0.25	1.10	0.80	32	BB4R/L-1232-TP60	■	■	□	□
		1.6	4.0	10	8.5	0.25-0.40	72-64	0.35	0.03	0.28	1.41	0.90	32	BB4R/L-1640-TP60	■	■	□	□
		2.5	6.0	10	8.5	0.35-0.50	56-48	0.44	0.04	0.34	2.25	1.35	32	BB4R/L-2560-TP60	■	■	□	□
			9.0	15	13.5	0.35-0.50	56-48	0.44	0.04	0.34	2.25	1.35	37	BB4R/L-2590-TP60	■	■	□	□
		3.3	8.0	15	13.5	0.50-0.75	40-36	0.62	0.06	0.48	2.97	1.50	37	BB4R/L-3380-TP60	■	■	□	□
			12.0	15	13.5	0.50-0.75	40-36	0.62	0.06	0.48	2.97	1.50	37	BB4R/L-33120-TP60	■	■	□	□
D h5	Holder	Ø min	L1	L2 BH6... BHY6...	L2 BHS6... BHK6...	P (mm)	P (TPI)	F	E (0/-0.01)	T	B	C	L3	Art. N°	R		L	
															ZTAF ZN	ZTAF ZN		
6	BH6... BHS6... BHY6... BHK6...	4.2	10.0	20	18.5	0.50-0.80	36-32	0.70	0.06	0.55	3.78	2.10	47	BB6R/L-42100-TP60	■	■	□	□
			15.0	20	18.5	0.50-0.80	36-32	0.70	0.06	0.55	3.78	2.10	47	BB6R/L-42150-TP60	■	■	□	□
		5.0	12.0	20	18.5	0.75-1.00	28-24	0.89	0.09	0.69	4.50	2.20	47	BB6R/L-50120-TP60	■	■	□	□
			18.0	20	18.5	0.75-1.00	28-24	0.89	0.09	0.69	4.50	2.20	47	BB6R/L-50180-TP60	■	■	□	□

Filetage

Gewindedrehen

Threading



BF4... / BF6...

TP60

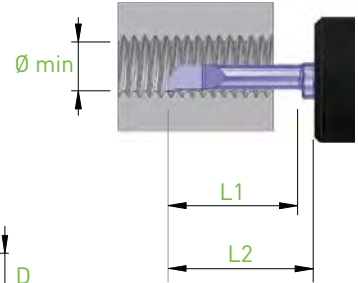
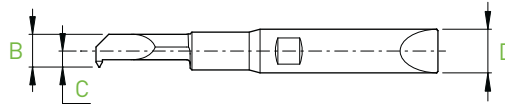
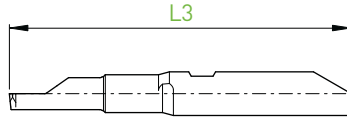
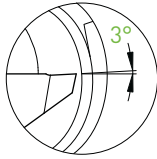
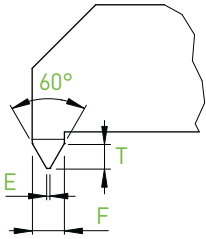

D h5	Holder	Ø min	L1	L2 BH4... BHY4...	L2 BHS4... BHK4...	P (mm)	P (TPI)	F	E (0/-0.01)	T	B	C	L3	Art. N°	R		L	
															ZTAF ZN	ZTAF ZN		
4	BH4... BHS4... BHY4... BHK4...	1.25	3.2	10	8.5	0.20-0.35	80	0.30	0.02	0.25	1.10	0.80	32	BF4R/L-1232-TP60	■	■	□	□
		1.6	4.0	10	8.5	0.25-0.40	72-64	0.35	0.03	0.28	1.41	0.90	32	BF4R/L-1640-TP60	■	■	□	□
		2.5	6.0	10	8.5	0.35-0.50	56-48	0.44	0.04	0.34	2.25	1.35	32	BF4R/L-2560-TP60	■	■	□	□
			9.0	15	13.5	0.35-0.50	56-48	0.44	0.04	0.34	2.25	1.35	37	BF4R/L-2590-TP60	■	■	□	□
		3.3	8.0	15	13.5	0.50-0.75	40-36	0.62	0.06	0.48	2.97	1.50	37	BF4R/L-3380-TP60	■	■	□	□
			12.0	15	13.5	0.50-0.75	40-36	0.62	0.06	0.48	2.97	1.50	37	BF4R/L-33120-TP60	■	■	□	□
D h5	Holder	Ø min	L1	L2 BH6... BHY6...	L2 BHS6... BHK6...	P (mm)	P (TPI)	F	E (0/-0.01)	T	B	C	L3	Art. N°	R		L	
															ZTAF ZN	ZTAF ZN		
6	BH6... BHS6... BHY6... BHK6...	4.2	10.0	20	18.5	0.50-0.80	36-32	0.70	0.06	0.55	3.78	2.10	47	BF6R/L-42100-TP60	■	■	□	□
			15.0	20	18.5	0.50-0.80	36-32	0.70	0.06	0.55	3.78	2.10	47	BF6R/L-42150-TP60	■	■	□	□
		5.0	12.0	20	18.5	0.75-1.00	28-24	0.89	0.09	0.69	4.50	2.20	47	BF6R/L-50120-TP60	■	■	□	□
			18.0	20	18.5	0.75-1.00	28-24	0.89	0.09	0.69	4.50	2.20	47	BF6R/L-50180-TP60	■	■	□	□

■ = disponible / verfügbar / available

□ = selon disponibilité du stock / jenach Lagerverfügbarkeit / depending the stock availability

IN-LINE

Filetage
Gewindedrehen
Threading



BB4... / BB6...

TP55

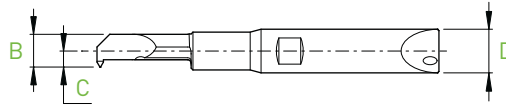
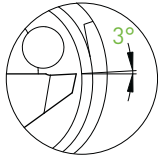
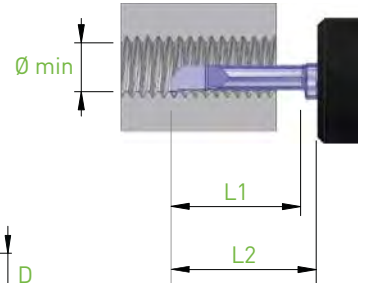
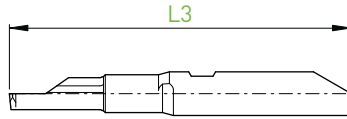
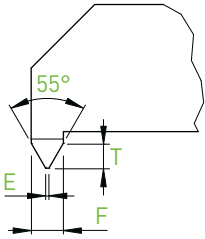

													R		L		
D _{h5}	Holder	Ø min	L1	L2 BH4... BHY4...	L2 BHS4... BHK4...	P (TPI)	F	E (0/-0.02)	T	B	C	L3	Art. N°	ZTAF ZN	ZTAF ZN		
4	BH4...	1.85	4.5	10	8.5	48	0.54	0.09	0.44	1.67	0.97	32	BB4R/L-1845-TP55	■	■	□	□
	BHS4...													■	■	□	□
	BHY4... BHK4...	2.55	6.0	10	8.5	40	0.64	0.10	0.52	2.25	1.35	32	BB4R/L-2560-TP55	■	■	□	□
D _{h5}	Holder	Ø min	L1	L2 BH6... BHY6...	L2 BHS6... BHK6...	P (TPI)	F	E (0/-0.02)	T	B	C	L3	Art. N°	ZTAF ZN	ZTAF ZN		
6	BH6...	3.70	11.0	20	18.5	32-24	1.08	0.13	0.91	3.33	1.83	47	BB6R/L-37110-TP55	■	■	□	□
	BHS6...	5.10	15.0	20	18.5	26-20	1.30	0.16	1.09	4.60	2.05	47	BB6R/L-51150-TP55	■	■	□	□
	BHY6... BHK6...	5.50	16.0	20	18.5	22-16	1.48	0.19	1.24	5.15	2.60	47	BB6R/L-55160-TP55	■	■	□	□

Filetage
Gewindedrehen
Threading



BF4... / BF6...

TP55

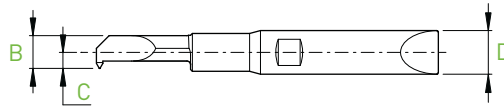
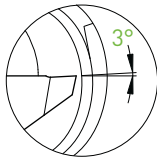
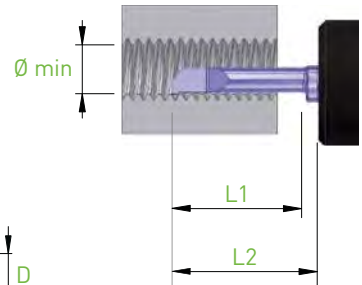
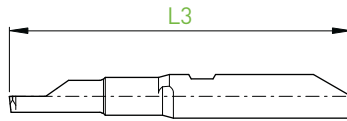
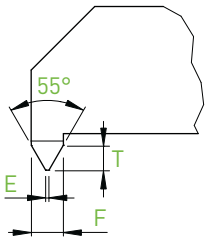

D _{h5}	Holder	Ø min	L1	L2 BH4... BHY4...	L2 BHS4... BHK4...	P (TPI)	F	E (0/-0.02)	T	B	C	L3	Art. N°	R		L	
														ZTAF ZN	ZTAF ZN	ZTAF ZN	ZTAF ZN
4	BH4...	1.85	4.5	10	8.5	48	0.54	0.09	0.44	1.67	0.97	32	BF4R/L-1845-TP55	■	■	□	□
	BHS4...																
	BHY4... BHK4...	2.55	6.0	10	8.5	40	0.64	0.10	0.52	2.25	1.35	32	BF4R/L-2560-TP55	■	■	□	□
D _{h5}	Holder	Ø min	L1	L2 BH6... BHY6...	L2 BHS6... BHK6...	P (TPI)	F	E (0/-0.02)	T	B	C	L3	Art. N°	R		L	
6	BH6...	3.70	11.0	20	18.5	32-24	1.08	0.13	0.91	3.33	1.83	47	BF6R/L-37110-TP55	■	■	□	□
	BHS6...																
	BHY6... BHK6...	5.10 5.50	15.0 16.0	20	18.5	26-20 22-16	1.30 1.48	0.16 0.19	1.09 1.24	4.60 5.15	2.05 2.60	47 47	BF6R/L-51150-TP55 BF6R/L-55160-TP55	■	■	□	□



Profil complet métrique
Metrisches Vollprofil
Metric full profile

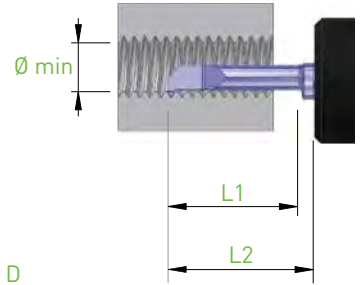
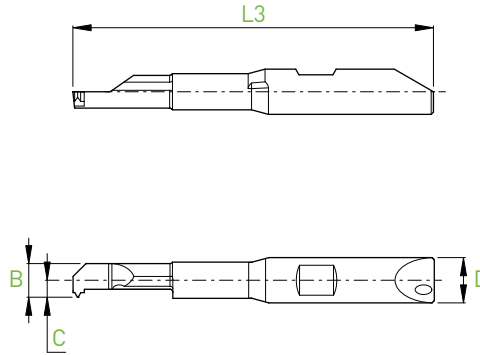
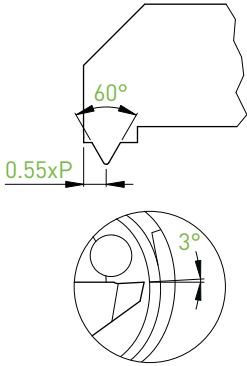

R

D h5	Holder	M (min)	Ø min	P (mm)	L1	L2 BH4... BHY4...	L2 BHS4... BHK4...	B	C	L3	Art. N°	ZTAF ZN
4	BH4... BHS4... BHY4... BHK4...	M3x0.5	2.50	0.50	6.0	10	8.5	2.25	1.35	32	BB4R-2560-TM-0.50	■ ■
		M4x0.7	3.30	0.70	8.0	15	13.5	2.97	1.50	37	BB4R-3380-TM-0.70	■ ■
D h5	Holder	M (min)	Ø min	P (mm)	L1	L2 BH6... BHY6...	L2 BHS6... BHK6...	B	C	L3	Art. N°	ZTAF ZN
6	BH6... BHS6... BHY6... BHK6...	M5x0.8	4.20	0.80	10.0	20	18.5	3.78	2.10	47	BB6R-42100-TM-0.80	■ ■
		M6x1.0	5.00	1.00	12.0	20	18.5	4.50	2.20	47	BB6R-50120-TM-1.00	■ ■

Filetage

Gewindedrehen

Threading



BF4... / BF6...

TM

Profil complet métrique

Metrisches Vollprofil

Metric full profile

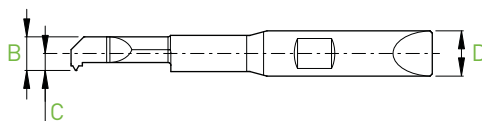
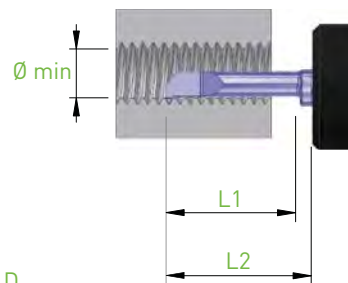
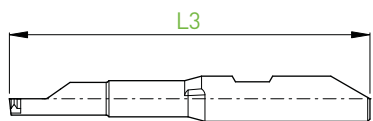
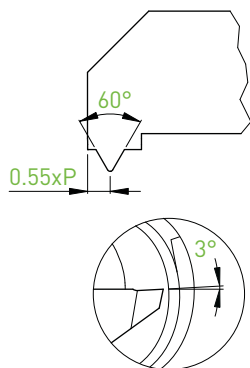

R

D _{h5}	Holder	M (min)	Ø min	P (mm)	L1	L2 BH4... BHY4...	L2 BHS4... BHK4...	B	C	L3	Art. N°	ZTAF	ZN
4	BH4... BHS4...	M3x0.5	2.50	0.50	6.0	10	8.5	2.25	1.35	32	BF4R-2560-TM-0.50	■	■
	BHY4... BHK4...	M4x0.7	3.30	0.70	8.0	15	13.5	2.97	1.50	37	BF4R-3380-TM-0.70	■	■
D _{h5}	Holder	M (min)	Ø min	P (mm)	L1	L2 BH6... BHY6...	L2 BHS6... BHK6...	B	C	L3	Art. N°	ZTAF	ZN
6	BH6... BHS6...	M5x0.8	4.20	0.80	10.0	20	18.5	3.78	2.10	47	BF6R-42100-TM-0.80	■	■
	BHY6... BHK6...	M6x1.0	5.00	1.00	12.0	20	18.5	4.50	2.20	47	BF6R-50120-TM-1.00	■	■

■ = disponible / verfügbar / available

□ = selon disponibilité du stock / jenach Lagerverfügbarkeit / depending the stock availability

IN-LINE

- Gorge frontale extérieure
- Aussen axiales stechen
- External axial grooving



BB6...

FEG

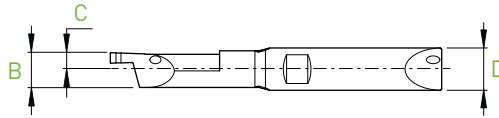
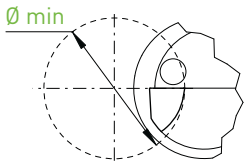
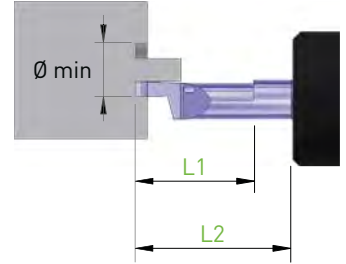
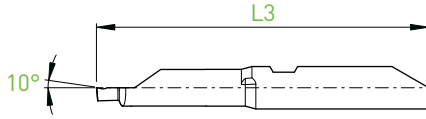
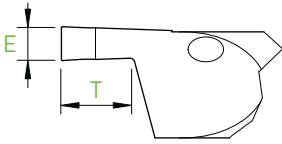

R

D h5	Holder	Ø min	L1	L2 BH6... BHY6...	L2 BHS6... BHK6...	T	B	C	E	L3	Art. N°	ZTAF	ZN
6	BH6... BHS6... BHY6... BHK6...	5.0	15.0	20	18.5	3.00	4.90	2.30	1.50	47	BB6R-50150-FEG150X	■	■

Gorge frontale intérieure

Innen axiales stechen

Internal axial grooving



BB6...

FIG

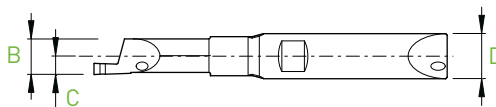
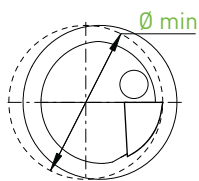
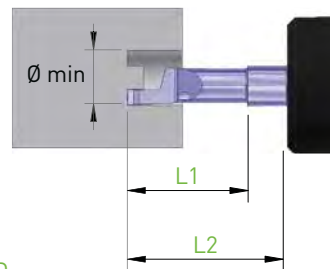
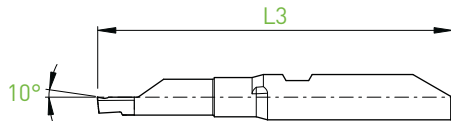
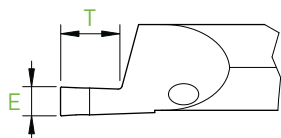

R

D h5	Holder	Ø min	L1	L2 BH6... BHY6...	L2 BHS6... BHK6...	T	B	C	E	L3	Art. N°	ZTAF	ZN
6	BH6... BHS6... BHY6... BHK6...	5.0	15.0	20	18.5	3.00	4.75	2.45	1.50	47	BB6R-50150-FIG150X	■	■

■ = disponible / verfügbar / available

□ = selon disponibilité du stock / jenach Lagerverfügbarkeit / depending the stock availability

IN-LINE

Ébauches avec arrosage
 Rohlinge mit Kühlung
 Blanks with coolant



BB4... / BB6...

BB_E

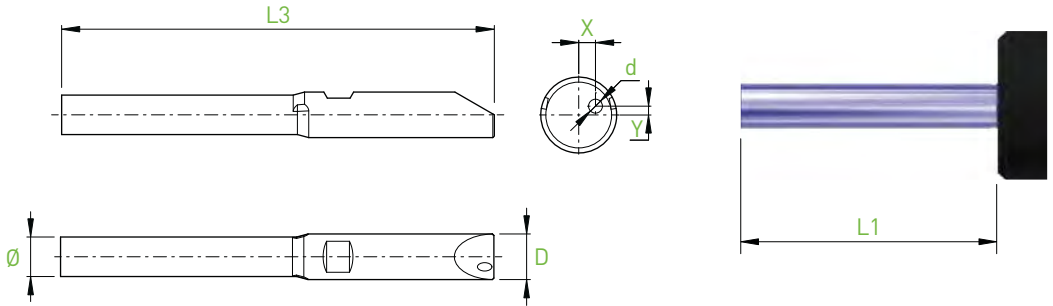

D_{h5}	Holder	L1 BH4... BHY4...	L1 BHS4... BHK4...	\emptyset	X	Y	d	L3	Art. N°	ZN
4	BH4... BHS4... BHY4... BHK4...	20.0	18.5	3.20	0.84	0.55	0.85	42	BB4R-E42	■
D_{h5}	Holder	L1 BH6... BHY6...	L1 BHS6... BHK6...	\emptyset	X	Y	d	L3	Art. N°	ZN
6	BH6... BHS6... BHY6... BHK6...	30.0	28.5	5.20	1.33	0.70	1.10	57	BB6R-E57	■

Ébauches

Rohlinge

Blanks



BF4... / BF6...

BF_E

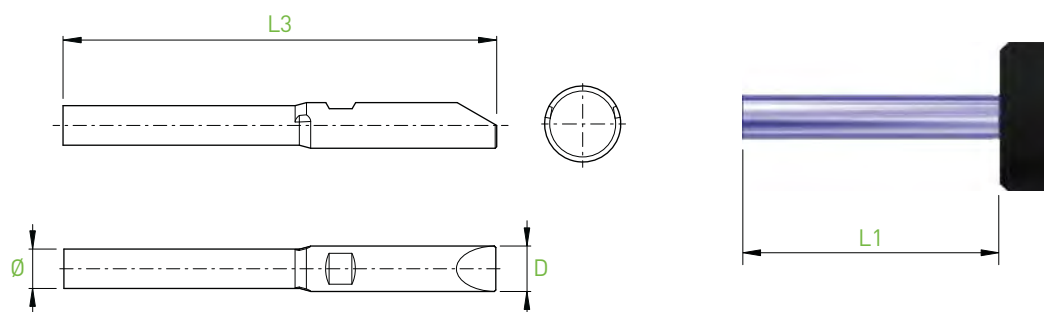

D_{h5}	Holder	L1 BH4... BHY4...	L1 BHS4... BHK4...	\emptyset	L3	Art. N°	ZN
4	BH4... BHS4... BHY4... BHK4...	20.0	18.5	3.20	42	BF4-E42	■
D_{h5}	Holder	L1 BH6... BHY6...	L1 BHS6... BHK6...	\emptyset	L3	Art. N°	ZN
6	BH6... BHS6... BHY6... BHK6...	30.0	28.5	5.20	57	BF6-E57	■

IN-LINE

Jauges d'alignement
Richtplatten
Adjusting tools

MASTER

BH4 / BH6

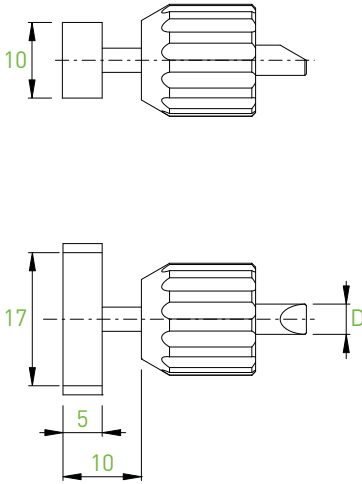

D h5	Art. N°	
4	BH4-MASTER	■
6	BH6-MASTER	■

Jauges d'alignement
Richtplatten
Adjusting tools

MASTER

BHSY...

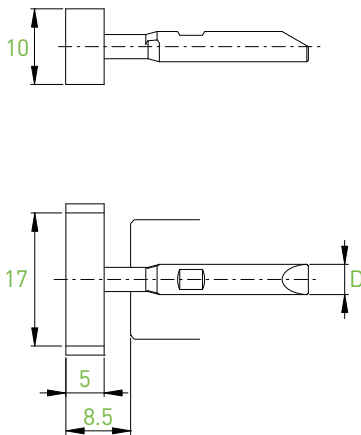

D h5	Art. N°	
4	BHSY4-MASTER	■
6	BHSY6-MASTER	■

Porte-outils avec arrosage pour contre-opération - Machines STAR
 Halter mit Kühlungssystem zur Gegenbearbeitung – STAR-Maschinen
 Backworking holders with through coolant – STAR-Machines

BH4 / BH6
 BHS4 / BHS6

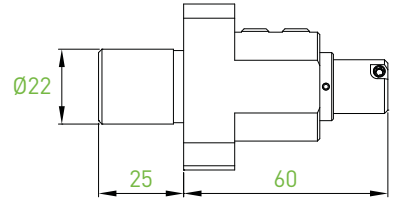
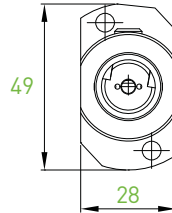

Art. N°

BWD1-2022-STAR-SRR



Art. N°

BHS4-D20-55-BWD1
 BHS6-D20-55-BWD1

Types of STAR machines

SR10J (T22+T24)
 SB16/20 Types C + D + E (T21-T24)
 SB20R Types E + G + N (T21-T24)
 SR20J / JN (T21-T24)
 SR20R / II / III (T21-T24)
 SR20R IV (T21-T24)
 SR32J/JN (T21-T24)
 SW12RII (T21-T24)
 SV20R (T21-T24)
 ECAS12/20 (T21-T24)
 SW20 (T21-T23)

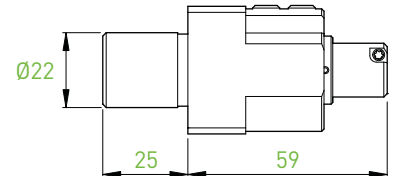
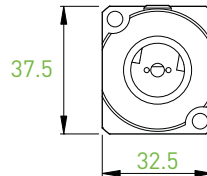

Art. N°

BWD1-2022-STAR-SW



Art. N°

BHS4-D20-55-BWD1
 BHS6-D20-55-BWD1

Types of STAR machines

SW12RII (T21-T28)
 SW20 (T21-T23 + T25-T27)
 SV20R (T21-T28)
 SR-20R IV (T21-T28)
 SB12/20R (T22-T24)
 SR38 (T21-T28)

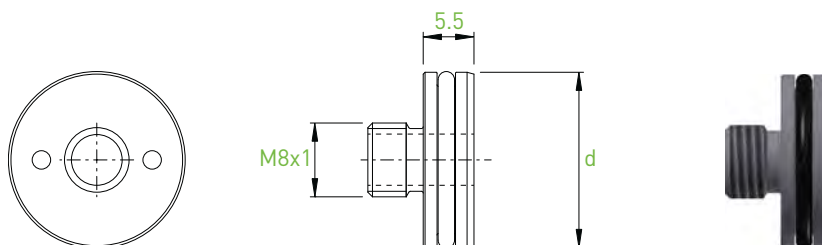

d	Art. N°	
19.05	JB-M8x1-D19.05	■
20	JB-M8x1-D20	■
22	JB-M8x1-D22	■
25	JB-M8x1-D25	■
25.4	JB-M8x1-D25.4	■